



TYPHOON INTAKE SYSTEMS

INTAKE SYSTEMS FOR VEHICLES LISTED ARE 50 STATE LEGAL. SEE KNFILTERS.COM FOR CARB STATUS ON EACH PART FOR A SPECIFIC VEHICLE.

INSTALLATION INSTRUCTIONS

69-2526TP
DODGE / CHRYSLER
 2009-19 Challenger
 2006-19 Charger
 2005-19 300C
 2005-08 Magnum R/T
V8-5.7L
 2008-10 Challenger SRT8
 2006-10 Charger SRT8
 2005-10 300C SRT8
 2006-08 Magnum SRT8
V8-6.1L

NOTE: Not designed to fit models equipped with SHAKER hoods.

TOOLS NEEDED:

- Ratchet
- Extension
- Flat Blade Screwdriver
- Pliers
- 10mm Socket
- 13mm Socket
- 10mm Wrench
- 5/8" Wrench

PARTS LIST:

Description	Qty.	Part #	Description	Qty.	Part #	Description	Qty.	Part #
A HOSE CLAMP #56	2	08620	L WASHER; 1/4" LOCK, ZN	1	08198	W NUT; 6MM NYLCOK, HEXHEAD, SS	3	07512
B HOSE; 3-1/2" ID 90DEG. ANGLED	1	084088	M WASHER; 1/4"ID X 5/8"OD - SAE	6	08275	X WASHER; 1"D X 1/4 HOLE FENDER	2	08160
C INTAKE TUBE	1	27442-1ATP	N GROMMET; 1"OD,1/2"ID,1/2"THK.	1	08064	Y BRACKET; SHORT TWIST, FIN.	1	070772A
D VENT; STRT 1/2" HOSE, 1/4"NPT	1	080022	O VENT; 90DEG., 1/2"HOSE,1/4"NPT	1	08110FK	Z BOLT; 8MM-1.25 X 20MM HEX HEAD	1	07787
E HOSE; 1/2" ID X 17" L	1	08177	P DODGE IAT EXTENSION HARNESS	1	21681	AA BRACKET; "L", SML, STL, FB/PC	1	070066A
F BOLT; M6-1.00 X 25MM, SS	1	07858	Q CABLE TIES; 11" BLACK	1	21590	AB HOSE CLAMP #104	1	08697
G WASHER; 8MM SPRING (WAVE)	1	08239	R EDGE TRIM (30")	1	102489A	AC ADAPTOR; #380	1	21512-1
H WASHER; 5/16"ID X 5/8"OD, FLAT	1	08276	S HOSE CLAMP #52	2	08610	AD AIR FILTER	1	RU-1042
I WASHER; 5/16"ID X 3/4"OD, 1/8"THK.	1	08129	T HOSE; 3-1/2" ID X 2" L REINFORCED	1	08698	AE IAT EXTENSION HARNESS	1	21680
J BRACKET; SM. "Z" MILD STL., FB/PC	1	010088A	U EDGE TRIM (39")	1	102496A			
K BOLT; 6MM-1.00 X 16MM, SS	3	07812	V HEAT SHIELD	1	07498A			

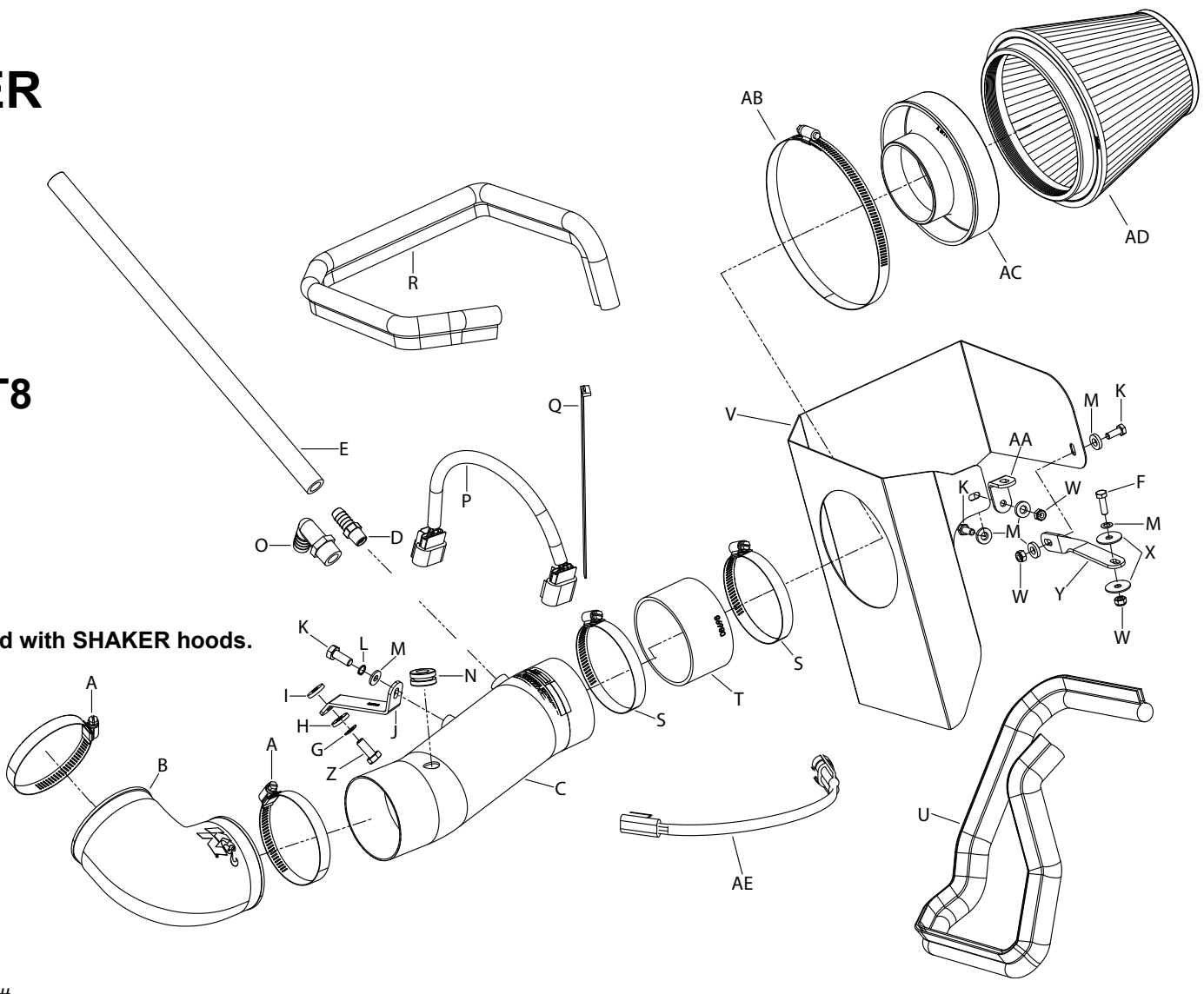

If you need any assistance please call 1-800-858-3333 to speak with a representative in our Customer Service Center before returning the product.

NOTE: FAILURE TO FOLLOW INSTALLATION INSTRUCTIONS AND NOT USING THE PROVIDED HARDWARE MAY DAMAGE THE INTAKE TUBE, THROTTLE BODY AND ENGINE.

TO START:

1. Turn off the ignition and disconnect the negative battery cable.
NOTE: Disconnecting the negative battery cable erases pre-programmed electronic memories. Write down all memory settings before disconnecting the negative battery cable. Some radios will require an anti-theft code to be entered after the battery is reconnected. The anti-theft code is typically supplied with your owner's manual. In the event your vehicles' anti-theft code cannot be recovered, contact an authorized dealership to obtain your vehicles anti-theft code.



2. Lift up the engine cover to loosen it from the mounts, and then remove the cover from the vehicle.



3. Release the red locking tap and then disconnect the inlet air temperature sensor electrical connection.
NOTE: Some vehicles may be equipped with an intake resonator near the inlet air temperature sensor.



4. Loosen the hose clamp that secures the intake tube to the throttle body and pull the intake tube off of the throttle body.



5. Disconnect the crankcase vent hose from the valve cover port as shown.



6. On SRT-8; 6.1L vehicles, disconnect the crankcase vent hose from the airbox as shown.



7. Loosen and remove the airbox mounting nut shown.



8. Lift and remove the complete intake assembly from the vehicle.
NOTE: K&N Engineering, Inc., recommends that customers do not discard factory air intake.



8a. On vehicles equipped with an intake resonator, remove the nut shown which secures the resonator bracket and then remove the resonator bracket from the engine.



9. Install the twist bracket (070772A) onto the core support using the provided hardware through the existing hole as shown.
NOTE: On vehicles equipped with HID headlights, the bracket mounting bolt will need to be installed from the bottom up. This may be difficult but it will fit.

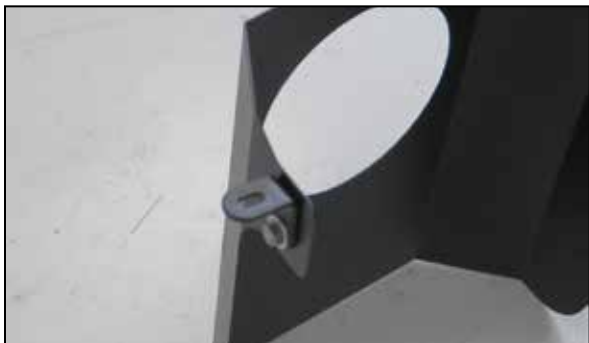

10. Install the "L" bracket (070066A) onto the heat shield with the provided hardware through the non-slotted hole in the bracket.



11. Install the two pieces of edge trim onto the heat shield as shown; be sure to leave a gap at the bracket mounting locations.



12. Install the heat shield assembly into the vehicle and secure to the bracket installed in step #9. Then secure the "L" bracket with the factory bolt removed in step #6 to the airbox mounting location.



12a. Due to vehicle manufacturing tolerances, the A/C lines on some vehicles may need to be repositioned slightly so that they do not contact the heat shield. To adjust, grab the A/C line on the aluminum section and carefully apply pressure in the desired direction until clearance is obtained.



13. Using the provided hardware, install the tube mounting bracket (010088A) onto the engine as shown. The 1/8" thick spacer (08129) should be placed between the bracket and engine.



14. Install the silicone hose (084088) onto the throttle body and secure with the provided hose clamp.



15. Remove the inlet air temperature sensor from the stock intake hose as shown.
NOTE: Be very careful when handling the inlet air temperature sensor as it is very fragile.
NOTE: The inlet air temperature sensor may be a different style than the one shown.



16. Install the provided grommet into the K&N® intake tube as shown.



17. Install the inlet air temperature sensor into the grommet installed in the previous step.

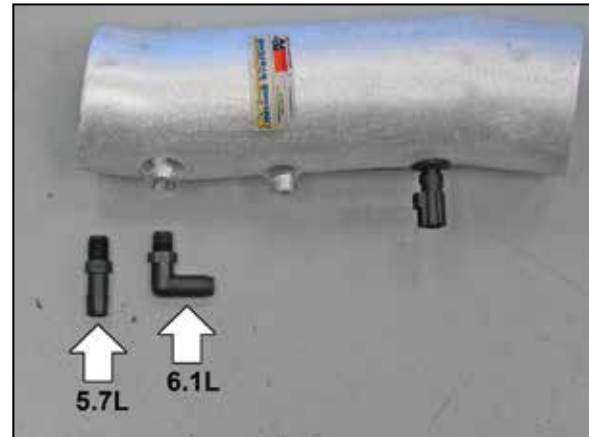

18. Install the appropriate 1/4npt fitting into the K&N® intake tube. The 90° fitting is for 6.1L engine size and the straight fitting is for 5.7L engine size.
NOTE: Plastic NPT fittings are easy to cross thread. Install the vent fitting "hand" tight, then turn it two complete turns with a wrench.



19. Install the K&N® intake tube into the silicone hose at the throttle body and align with the heat shield and mounting bracket. Secure the intake tube with the hose clamp and hardware provided.



20. Install the provided crankcase vent hose onto the vent port on the valve cover and then connect the open end to the fitting installed into the K&N® intake tube. Some trimming of the crankcase vent hose may be necessary.



21. Connect the provided inlet air temperature sensor harness extension into the factory harness, run it under the throttle body and then connect to the inlet air temperature sensor as shown. Using the provided cable tie, secure the harness extension tube mounting bracket.
NOTE: Inspect the inlet air temperature sensor to determine which of the two provided harnesses will be needed.



22. Install the provided air filter adapter into the K&N® air filter and secure with the provided hose clamp.

NOTE: Drycharger® air filter wrap; part # RF-1042DK is available to purchase separately. To learn more about Drycharger® filter wraps or look up color availability please visit <http://www.knfilters.com>®.



23. Install the provided silicone hose (08698) onto the filter adapter and secure with the provided hose clamp.



24. Install the filter assembly onto the K&N® intake tube and secure with the provided hose clamp.



25. Reinstall the engine cover onto the engine.



25a. It may be necessary on some vehicles to trim the engine cover as shown to clear the tube mounting bracket.



26. Reconnect the vehicle's negative battery cable. Double check to make sure everything is tight and properly positioned before starting the vehicle.

27. The C.A.R.B. exemption sticker, (attached), must be visible under the hood so that an emissions inspector can see it when the vehicle is required to be tested for emissions. California requires testing every two years, other states may vary.

28. It will be necessary for all K&N® high flow intake systems to be checked periodically for realignment, clearance and tightening of all connections. Failure to follow the above instructions or proper maintenance may void warranty.

ROAD TESTING:

1. Start the engine with the transmission in neutral or park, and the parking brake engaged. Listen for air leaks or odd noises. For air leaks secure hoses and connections. For odd noises, find cause and repair before proceeding. This kit will function identically to the factory system except for being louder and much more responsive.

2. Test drive the vehicle. Listen for odd noises or rattles and fix as necessary.

3. If road test is fine, you can now enjoy the added power and performance from your kit.

4. K&N Engineering, Inc., requires cleaning the intake system's air filter element every 100,000 miles. When used in dusty or off-road environments, our filters will require cleaning more often. We recommend that you visually inspect your filter once every 25,000 miles to determine if the screen is still visible. When the screen is no longer visible some place on the filter element, it is time to clean it. To clean and re-oil, purchase our filter Recharger® service kit, part number 99-5050 or 99-5000 and follow the easy instructions.

INTAKE SYSTEMS FOR VEHICLES LISTED ARE 50 STATE LEGAL. SEE KNFILTERS.COM FOR CARB STATUS ON EACH PART FOR A SPECIFIC VEHICLE.