



TYPHOON INTAKE SYSTEMS

INTAKE SYSTEMS FOR VEHICLES LISTED ARE 50 STATE LEGAL. SEE KNFILTERS.COM FOR CARB STATUS ON EACH PART FOR A SPECIFIC VEHICLE.

INSTALLATION INSTRUCTIONS

69-2544TP CHRYSLER / DODGE 2011-18 Challenger 2011-18 Charger 2011-18 300 V6-3.6L

TOOLS NEEDED:

- 4mm Allen Wrench
- 10mm Socket
- 14mm Socket
- 10mm Wrench
- Extension
- Flat Blade Screwdriver
- Ratchet

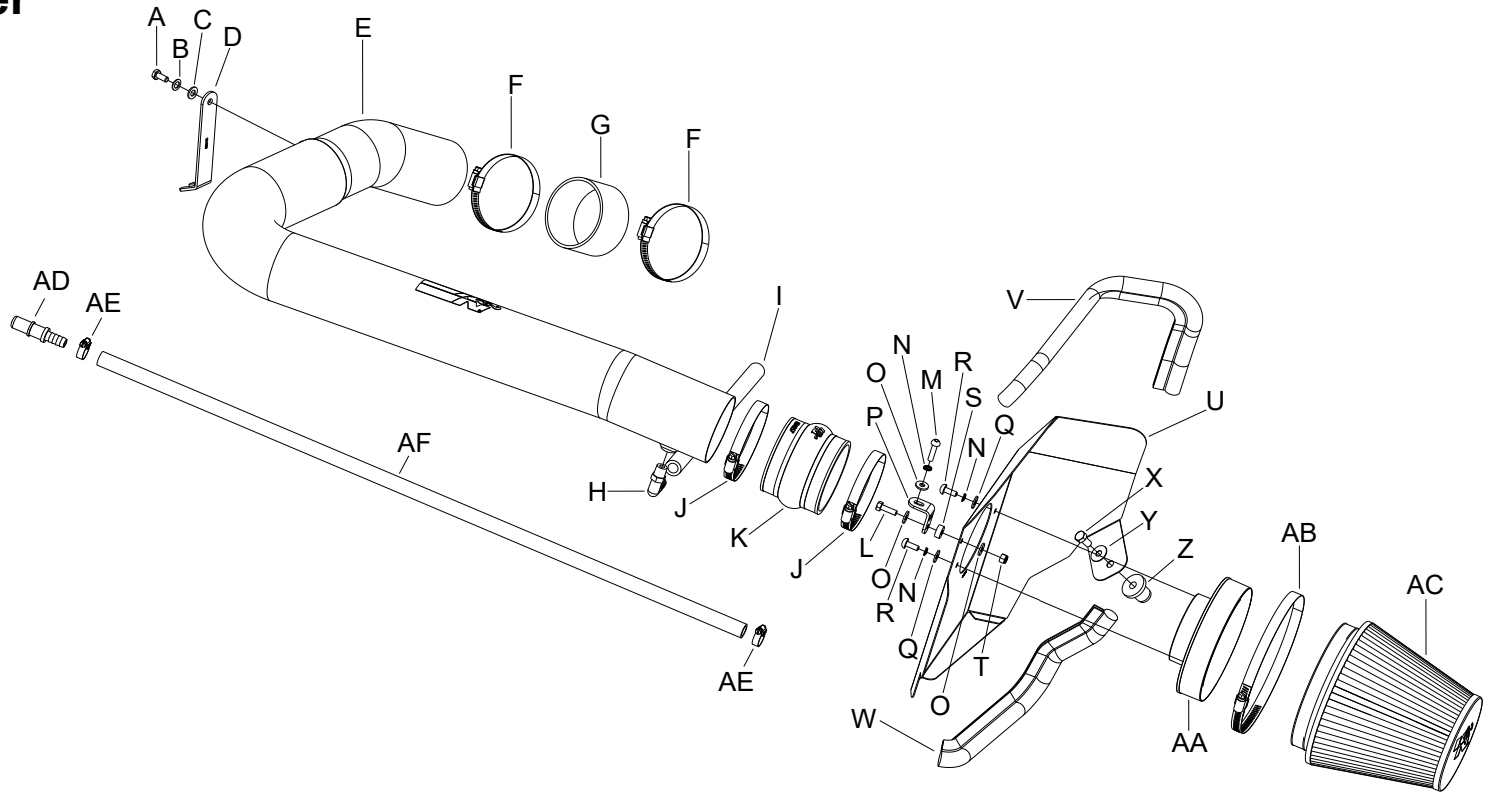

PARTS LIST:

Description	Qty.	Part #
A BOLT; M8 X 1 X 20M M, TAP	1	06533
B WASHER; 8MM SPRING (WAVE)	1	08239
C WASHER; 3/8" FLAT WASHER, SS	1	08134
D BRACKET; "L", STL, TK/PC	1	083153
E INTAKE TUBE	1	27492TP
F HOSE CLAMP # 52	2	08610
G HOSE; 3-1/4" ID X 2"L REINFORCED	1	08690
H VENT; 90DEG, 1/2" HOSE, 1/4"NPT, BLK.	1	08110FK
I HOSE; 1/2"ID X 14"L	1	08402
J HOSE CLAMP #56	2	08620
K HOSE; 3-1/2" ID X 3" L HUMP MOLDED	1	084057
L BOLT; M6 X 1.00" X 20MM HEX, SS	1	07795
M BOLT; M6-1.00 X 25MM BTNHD, SS	1	07729
N WASHER; M6 SPLIT LOCK ZINC	3	1-3025
O WASHER; 1/4" ID X 5/8" OD-SAE	3	08275
P BRACKET; "L", SML, STL, TB/PC	1	070066A
Q WASHER; 6MM FLAT, SS	2	08269
R BOLT; M6 X 1.00 X 16MM, BTNHD, SS	2	07730
S SPACER; .625" OD X .250"ID X .250"L	1	06555
T NUT; 6MM NYLOCK, HEXHEAD, SS	1	07512
U HEAT SHIELD	1	074088A
V EDGE TRIM (20")	1	102494A
W EDGE TRIM (15")	1	102474A
X BOLT; 3/8"-16 X 1-1/4"L SS HEX HEAD BOLT	1	07779
Y WASHER; 8MM, FLAT, SS	1	08272
Z INSERT; 3/8-16 X 3/400 X 15/16L, RUBBER	1	08163
AA ADAPTER; UNIVERSAL, 6" FILTER 3.5"	1	21512-1
AB HOSE CLAMP # 104	1	08697
AC AIR FILTER	1	RU-1042
AD FITTING; VENT, 1/2" BARB QUICK CONNECT	1	82629
AE HOSE CLAMP; #6 MINI	2	08407
AF HOSE; 1/2"ID X 35"L	1	5-5035

If you need any assistance please call 1-800-858-3333 to speak with a representative in our Customer Service Center before returning the product.

NOTE: FAILURE TO FOLLOW INSTALLATION INSTRUCTIONS AND NOT USING THE PROVIDED HARDWARE MAY DAMAGE THE INTAKE TUBE, THROTTLE BODY AND ENGINE.

TO START:

1. Turn off the ignition and disconnect the negative battery cable.

NOTE: Disconnecting the negative battery cable erases pre-programmed electronic memories. Write down all memory settings before disconnecting the negative battery cable. Some radios will require an anti-theft code to be entered after the battery is reconnected. The anti-theft code is typically supplied with your owner's manual. In the event your vehicles' anti-theft code cannot be recovered, contact an authorized dealership to obtain your vehicles anti-theft code.



2. Lift up and remove the engine cover and remove it from the engine.



3. Disconnect the inlet air temperature sensor electrical connection.



4. Disconnect the crankcase vent hose from the air filter housing.
NOTE: On later models the crank case vent line connection will be near the throttle body.



5. Loosen the hose clamp that secures the intake tube to the throttle body.



6. Remove the bolt that secures the air filter housing to the core support.



7. Remove the complete stock intake system from the vehicle.

NOTE: K&N Engineering, Inc., recommends that customers do not discard factory air intake.

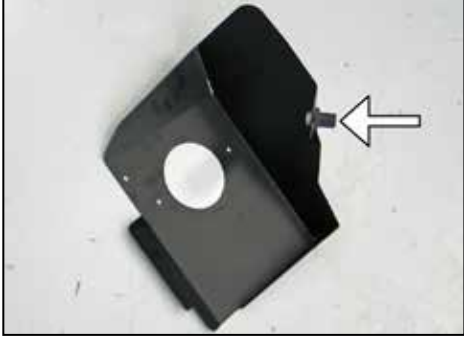

8. Install the inserted nut onto the heat shield using the provided hardware as shown.



9. Install the heat shield mounting bracket (070066A) onto the heat shield as shown using the provided hardware and spacer.



10. Install the provided longer edge trim onto the top of the heat shield as shown.

NOTE: trimming of the edge trim will be necessary.



11. Install the provided shorter edge trim onto the bottom of the heat shield as shown.

NOTE: trimming of the edge trim will be necessary.



12. Install the filter adapter into the heat shield and secure with the provided hardware.



13. Install the silicone hump hose (084057) onto the filter adapter and secure with the provided hose clamp.



14. Install the heat shield assembly onto the inner fender; secure the mounting bracket to the factory airbox mounting location with the provided hardware. The inserted nut is to be placed in the hole of the inner fender and then secured by tightening the assembly's bolt.



15. Install the provided silicone hose (08690) onto the throttle body and secure with the provided hose clamp.



16. Rotate the inlet air temperature sensor counter clockwise and then remove from the factory intake tube.

NOTE: The inlet air temperature sensor is very fragile.



17. Install the inlet air temperature sensor into the K&N® intake tube as shown, turning the sensor clockwise to lock.

NOTE: The inlet air temperature sensor is very fragile.



18. Install the 90° NPT fitting into the K&N® intake tube as shown.

NOTE: Plastic NPT fittings are easy to cross thread. Install the vent fitting "hand" tight, then turn it two complete turns with a wrench.



19. Install the K&N® intake tube into the silicone hump hose and then into the silicone hose on the throttle body.

NOTE: Do not tighten the hose clamps at this time.



20. Remove the intake plenum mount grommet from the intake plenum.

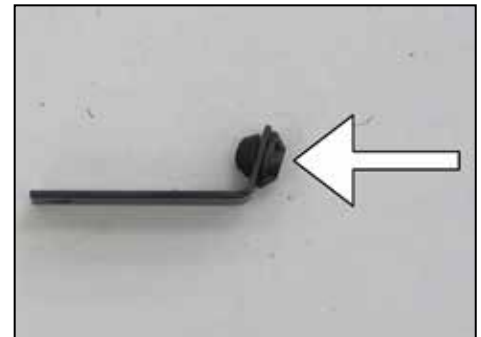

21. Install the mounting grommet from the intake plenum into the provided tube bracket as shown.



22. Install the tube bracket onto the mounting stud and then secure to the K&N® intake tube with the provided hardware. Tighten the hose clamps at this time.



23. Reconnect the inlet air temperature sensor electrical connection.



24. Install the provided silicone hose onto the factory crankcase vent tube and then connect the open end to the 90° fitting installed into the K&N® intake tube.

NOTE: On later model vehicles that the CCV connection is near the throttle body, it will be necessary to use the provided quick connect fitting and longer CCV hose.



25. Install the K&N® air filter and secure with the provided hose clamp.

NOTE: Drycharger® air filter wrap; part # RF-1042DK is available to purchase separately. To learn more about Drycharger® filter wraps or look up color availability please visit <http://www.knfilters.com>®.



26. Reinstall the engine cover.



27. Reconnect the vehicle's negative battery cable. Double check to make sure everything is tight and properly positioned before starting the vehicle.

28. The C.A.R.B. exemption sticker, (attached), must be visible under the hood so that an emissions inspector can see it when the vehicle is required to be tested for emissions. California requires testing every two years, other states may vary.

29. It will be necessary for all K&N® high flow intake systems to be checked periodically for realignment, clearance and tightening of all connections. Failure to follow the above instructions or proper maintenance may void warranty.

ROAD TESTING:

1. Start the engine with the transmission in neutral or park, and the parking brake engaged. Listen for air leaks or odd noises. For air leaks secure hoses and connections. For odd noises, find cause and repair before proceeding. This kit will function identically to the factory system except for being louder and much more responsive.

2. Test drive the vehicle. Listen for odd noises or rattles and fix as necessary.

3. If road test is fine, you can now enjoy the added power and performance from your kit.

4. K&N Engineering, Inc., requires cleaning the intake system's air filter element every 100,000 miles. When used in dusty or off-road environments, our filters will require cleaning more often. We recommend that you visually inspect your filter once every 25,000 miles to determine if the screen is still visible. When the screen is no longer visible some place on the filter element, it is time to clean it. To clean and re-oil, purchase our filter Recharger® service kit, part number 99-5050 or 99-5000 and follow the easy instructions.

INTAKE SYSTEMS FOR VEHICLES LISTED ARE 50 STATE LEGAL. SEE KNFILTERS.COM FOR CARB STATUS ON EACH PART FOR A SPECIFIC VEHICLE.