



LEGAL IN CALIFORNIA ONLY FOR RACING VEHICLES WHICH MAY NEVER BE USED, REGISTERED OR LICENSED FOR USE UPON A HIGHWAY. See knfilters.com for CARB status on each part for a specific vehicle

INSTALLATION INSTRUCTIONS

77-1562KTK
JEEP / DODGE
2010-12 Liberty
2010-11 Nitro
V6-3.7L

NOTE: This kit was not designed to fit vehicles with a body lift.

TOOLS NEEDED:

Ratchet
 Extension
 13mm Socket
 10mm Socket
 8mm Socket
 3/4" Wrench
 10mm Wrench
 Flat Blade Screwdriver
 4mm Allen Wrench

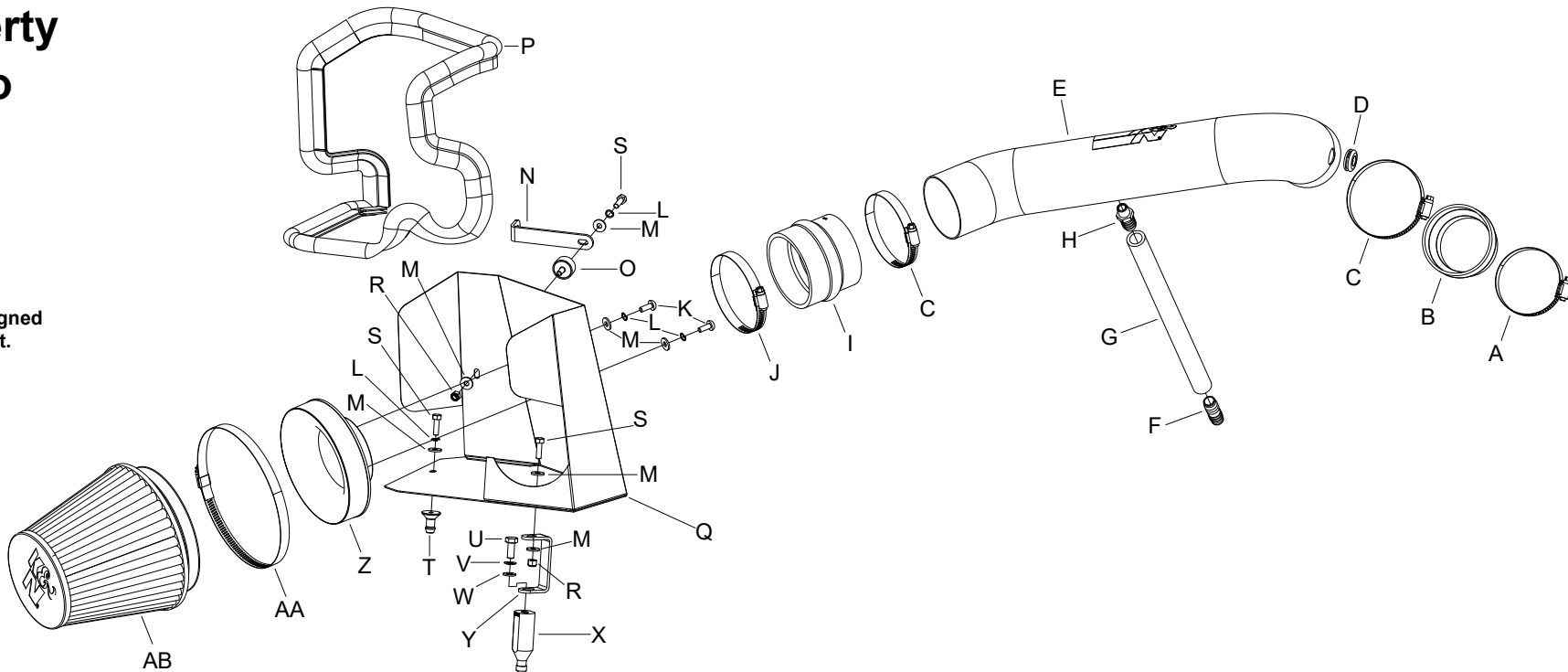

PARTS LIST:

Description	Qty.	Part #	Description	Qty.	Part #	Description	Qty.	Part #
A HOSE CLAMP; #44	1	08560	K BOLT; M6 X 1 X 16MM	2	07730	U BOLT; 8MM-1.25 X 20MM	1	07787
B HOSE; 3.25" TO 2.75"ID X 2"L	1	084034	L WASHER; 1/4" LOCK	4	08198	V WASHER; 8MM SPRING	1	08239
C HOSE CLAMP; #52	2	08610	M WASHER; 1/4"ID X 5/8"OD	7	08275	W WASHER; 8MM FLAT	1	08272
D GROMMET; 1-1/16OD	1	080544	N BRACKET; "L"	1	070952A	X STANDOFF; 6.0 FORD	1	06532
E INTAKE TUBE; (AL)	1	27486TK	O STUD; RUBBER	1	070228	Y BRACKET; "C"	1	083151
F FITTING; VENT 5/8"OD	1	08048	P EDGE TRIM; #61	1	102492A	Z ADAPTER; 6" FILTER	1	21512-1
G HOSE; 5/8"ID X 13"L	1	08602	Q HEAT SHIELD	1	074084	AA HOSE CLAMP; #104	1	08697
H FITTING; VENT 1/4"NPT	1	08911-2	R NUT; 6MM NYLOCK	2	07512	AB AIR FILTER	1	RU-1042
I HOSE; HUMP 3.25" / 3.5"	1	5-576	S BOLT; M6 X 1 X 20MM	3	07795			
J HOSE CLAMP; #56	1	08620	T MOUNT; PLASTIC AIRBOX	1	8-186-1			

If you need any assistance please call 1-800-858-3333 to speak with a representative in our Customer Service Center before returning the product.

NOTE: FAILURE TO FOLLOW INSTALLATION INSTRUCTIONS AND NOT USING THE PROVIDED HARDWARE MAY DAMAGE THE INTAKE TUBE, THROTTLE BODY AND ENGINE.

TO START:

1. Turn off the ignition and disconnect the negative battery cable.

NOTE: Disconnecting the negative battery cable erases pre-programmed electronic memories. Write down all memory settings before disconnecting the negative battery cable. Some radios will require an anti-theft code to be entered after the battery is reconnected. The anti-theft code is typically supplied with your owner's manual. In the event your vehicles anti-theft code cannot be recovered, contact an authorized dealership to obtain your vehicles anti-theft code.



2. Release the red locking tab and then disconnect the inlet air temp sensor electrical connection.



3. Disconnect the crankcase vent hose at the rear of engine, leaving elbow attached to cylinder head.



4. Release the two upper airbox retaining clips.



5. Loosen hose clamp at throttle body.



6. Remove the upper airbox and intake tube assembly from the vehicle.
NOTE: K&N Engineering, Inc., recommends that customers do not discard factory air intake.



7. Lift up the lower airbox assembly to dislodge it from the mounting grommets, then disconnect the fresh air duct from the lower airbox and then remove the lower airbox from the vehicle.



8. Install the silicone hose (084034) onto the throttle body and secure with the provided hose clamp.

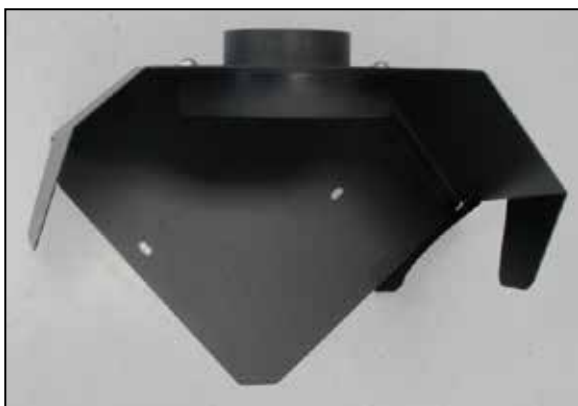

9. Attach the filter adapter into the heat shield as shown, and secure with the provided hardware.



10. Install the provided edge trim onto the heat shield as shown.
NOTE: Some trimming of the edge trim will be necessary.



11. Install rubber mounted stud onto the heat shield mounting bracket (070952) as shown using the provided hardware.



12. Install the heat shield mounting bracket assembly onto the heat shield using the provided hardware.



13. Install the silicone hump hose (5-576) onto the filter adapter and secure with provided hose clamp.



14. Install the heat shield mounting standoff onto the mounting bracket (083151) using the provided hardware as shown.



15. Install the bracket/stand-off assembly onto the heat shield using the hardware provided as shown.



16. Attach the short standoff assembly to the heat shield and secure with the provided hardware as shown.



17. Remove the front upper ECU mounting bolt shown.

NOTE: This bolt will be reused.



18. Place the heat shield assembly into vehicle so the mounting standoffs are secured in the factory airbox mounting grommets. Secure the mounting bracket to the ECU using the bolt removed in step #17.



19. Install the provided NPT vent fitting into the K&N® intake tube as shown.

NOTE: NPT fitting has tapered threads and only designed to be installed until hand tight, then tighten ONE rotation or when the fitting becomes difficult to return.



20. Install the provided grommet into the K&N® intake tube as shown.



21. Remove inlet air temperature sensor from factory tube as shown.

NOTE: The inlet air temperature sensor is very fragile, use care when removing the sensor.



22. Install the inlet air temperature sensor into the grommet previously installed during step #21.
NOTE: The inlet air temperature sensor is very fragile, use care when installing the sensor.



23. Install K&N® intake tube into the silicone hose at the filter adapter and then into the silicone hose on the throttle body. Secure the intake tube with the provided hose clamps.



24. Install the provided hose mender into the provided crankcase vent hose as shown.



25. Install the crankcase vent hose onto the NPT fitting on the K&N® intake tube. Install the hose mender end into the factory elbow on the valve cover.

NOTE: Some trimming may be necessary.

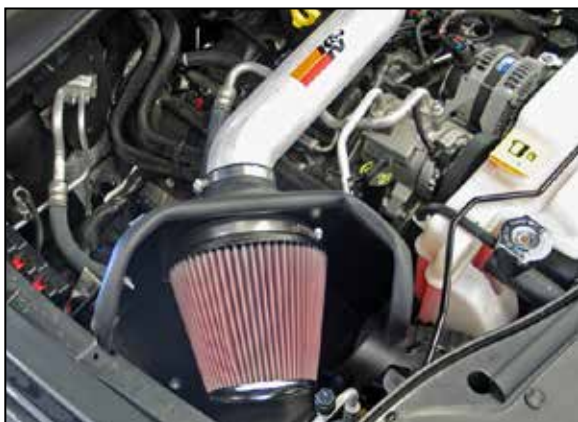

26. Install the K&N® air filter onto the filter adapter and secure with the provided hose clamp.
NOTE: Drycharger® air filter wrap; part # RF-1042DK is available to purchase separately. To learn more about Drycharger® filter wraps or look up color availability please visit <http://www.knfilters.com>.



27. Reconnect the inlet air temperature sensor electrical connector as shown.



28. Reconnect the vehicle's negative battery cable. Double check to make sure everything is tight and properly positioned before starting the vehicle.

29. It will be necessary for all K&N® high flow intake systems to be checked periodically for realignment, clearance and tightening of all connections. Failure to follow the above instructions or proper maintenance may void warranty.

ROAD TESTING:

1. Start the engine with the transmission in neutral or park, and the parking brake engaged. Listen for air leaks or odd noises. For air leaks secure hoses and connections. For odd noises, find cause and repair before proceeding. This kit will function identically to the factory system except for being louder and much more responsive.

2. Test drive the vehicle. Listen for odd noises or rattles and fix as necessary.

3. If road test is fine, you can now enjoy the added power and performance from your kit.

4. K&N Engineering, Inc., requires cleaning the intake system's air filter element every 100,000 miles. When used in dusty or off-road environments, our filters will require cleaning more often. We recommend that you visually inspect your filter once every 25,000 miles to determine if the screen is still visible. When the screen is no longer visible some place on the filter element, it is time to clean it. To clean and re-oil, purchase our filter Recharger® service kit, part number 99-5050 or 99-5000 and follow the easy instructions.

LEGAL IN CALIFORNIA ONLY FOR RACING VEHICLES WHICH MAY NEVER BE USED, REGISTERED OR LICENSED FOR USE UPON A HIGHWAY.

See [knfilters.com](http://www.knfilters.com) for CARB status on each part for a specific vehicle