



INTAKE SYSTEMS FOR VEHICLES LISTED ARE 50 STATE LEGAL. SEE KNFILTERS.COM FOR CARB STATUS ON EACH PART FOR A SPECIFIC VEHICLE.

INSTALLATION INSTRUCTIONS

77-1564KS
RAM
2013-14 Ram 1500
V6-3.6L

NOTE: This kit was not designed to fit vehicles with a body lift.

TOOLS NEEDED:

- Flat Blade screw driver
- Ratchet
- Extension
- 13mm socket
- 4mm allen key.

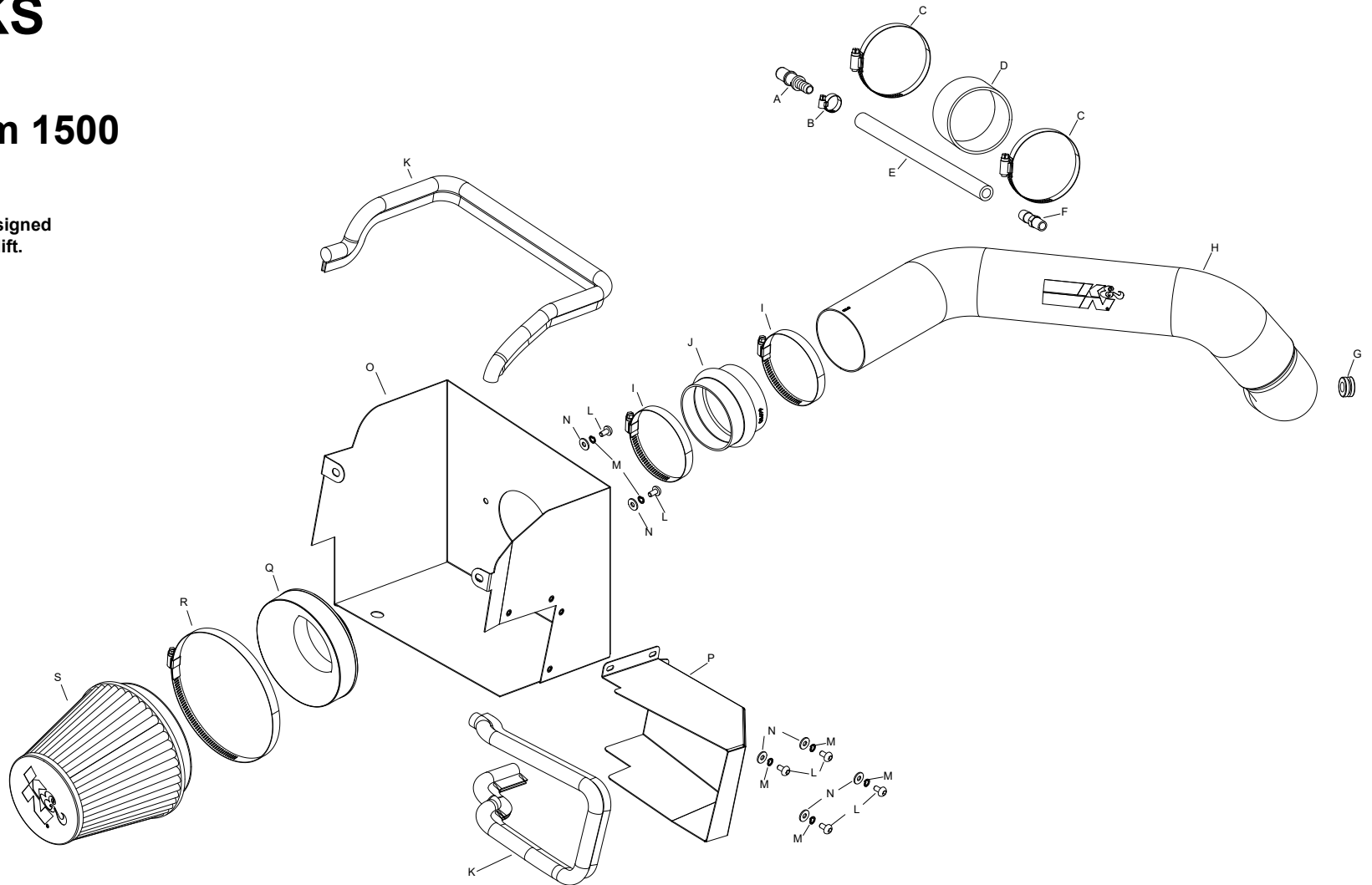

PARTS LIST:

Description	Qty.	Part #	Description	Qty.	Part #	Description	Qty.	Part #
A FITTING; VENT, 1/2" BARB	1	82629	H INTAKE TUBE; AL	1	27622KS	N WASHER; 6MM FLAT	6	08269
B HOSE CLAMP #6 MINI	1	08407	I HOSE CLAMP #56	2	08620	O HEAT SHIELD	1	073173
C HOSE CLAMP #52	2	08610	J HOSE HUMP; 3.5"ID X 2.5"L	1	08699	P HEAT SHIELD; SCOOP	1	073174
D HOSE; 3.25" ID X 2"L	1	08690	K EDGE TRIM; 55"L	1	102480A	Q ADAPTER; 6" FILTER	1	21512-1
E HOSE; 1/2"ID X 12"L	1	087031	L BOLT; M6-1 X 12MM	6	07794	R HOSE CLAMP #104	1	08697
F VENT; STRT 1/2" HOSE, 1/4"	1	080022	M WASHER, M6 SPLIT LOCK ZINC	6	1-3025	S AIR FILTER	1	RU-1042
G GROMMET; 1" OD, 1/2" ID, 1/2"	1	08064						

If you need any assistance please call 1-800-858-3333 to speak with a representative in our Customer Service Center before returning the product.

NOTE: FAILURE TO FOLLOW INSTALLATION INSTRUCTIONS AND NOT USING THE PROVIDED HARDWARE MAY DAMAGE THE INTAKE TUBE, THROTTLE BODY AND ENGINE.

TO START:

1. Turn off the ignition and disconnect the negative battery cable.
NOTE: Disconnecting the negative battery cable erases pre-programmed electronic memories. Write down all memory settings before disconnecting the negative battery cable. Some radios will require an anti-theft code to be entered after the battery is reconnected. The anti-theft code is typically supplied with your owner's manual. In the event your vehicles anti-theft code cannot be recovered, contact an authorized dealership to obtain your vehicles anti-theft code.



2. Disconnect the Inlet air temperature sensor electrical connection and loosen the hose clamp securing the intake plenum to the throttle body.



3. Disconnect the crank case vent from the intake plenum.



4. Loosen the hose clamp securing the intake hose to the factory air box.

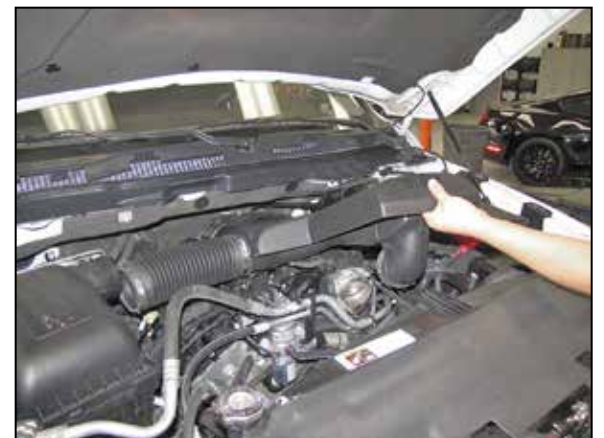

5. Lift up the intake plenum to dislodge it from the mounting grommets and then remove the plenum from the vehicle.



6. Lift the air box assembly off of the mounting studs and then remove the air box from the vehicle. **NOTE: K&N Engineering, Inc., recommends that customers do not discard factory air intake.**



7. Install the K&N® fresh air intake scoop onto the K&N® heat shield and secure with the provided hardware.

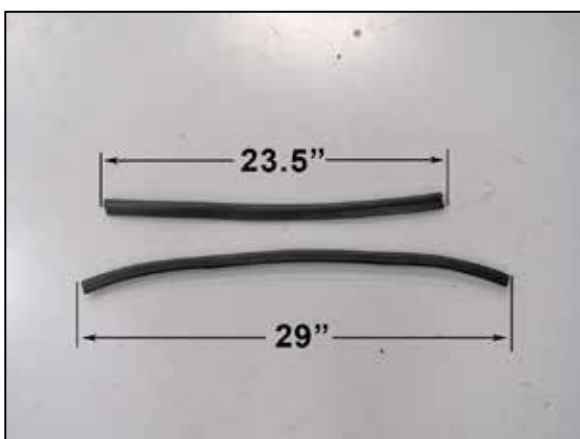

8. Cut the provided edge trim into two sections. One section will be 29" long; the other section will be 23.5" long.

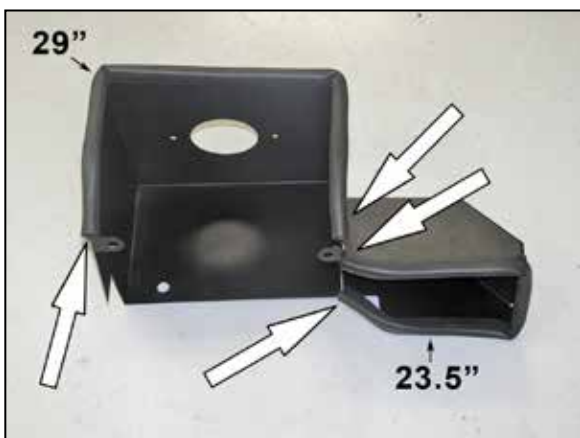

9. Install the two sections of edge trim onto the heat shield and fresh air intake scoop as shown. The 29" section will be installed onto the heat shield and the 23.5" section will be installed onto the fresh air intake scoop.



10. Remove one of the rubber mounting grommets from the factory air box.



11. Install the factory rubber mounting grommet into the K&N® heat shield as shown.



12. Install the K&N® air filter adapter into the heat shield and secure with the provided hardware.



13. Install the K&N® air filter onto the filter adapter and secure with the provided hose clamp.
NOTE: Drycharger® air filter wrap; part # RF-1042DK is available to purchase separately. To learn more about Drycharger® filter wraps or look up color availability please visit <http://www.knfilters.com>®.

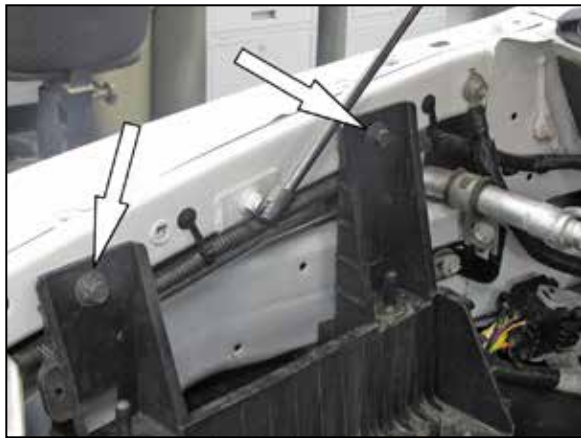

14. Remove the two factory air box mounting bracket bolts shown.
NOTE: These bolts will be reused in the next step.



15. Set the heat shield into position on the factory air box mounting bracket and then secure with the factory bolts removed on step #14.



16. Install the provided silicone hose (08699) onto the filter adapter and secure with the provided hose clamp.



17. Install the provided silicone hose (08690) onto the throttle body and secure with the provided hose clamp.



18. Install the provided grommet into the K&N® intake tube.



19. Remove the inlet air temperature sensor from the factory intake plenum.



20. Install the inlet air temperature sensor into the grommet installed into the K&N® intake tube.
NOTE: Remove the factory sealing O-ring from the sensor before installation.



21. Install the provided vent fitting into the K&N® intake tube as shown.
NOTE: Plastic NPT fittings are easy to cross thread. Install the vent fitting "hand" tight, then turn it two complete turns with a wrench.



22. Install the K&N® intake tube assembly into the coupler hose at the filter adapter and then into the coupler hose at the throttle body. Adjust the tube for best fit and then secure with the provided hose clamps.



23. Reconnect the inlet air temperature sensor electrical connection.



24. Install the provided quick disconnect fitting into the provided crank case vent hose and secure with the provided hose clamp.



25. Install the crank case vent hose assembly onto the fitting installed into the K&N® intake tube and then connect the quick disconnect fitting into the factory connector as shown.



26. Reconnect the vehicle's negative battery cable. Double check to make sure everything is tight and properly positioned before starting the vehicle.

27. The C.A.R.B. exemption sticker, (attached), must be visible under the hood so that an emissions inspector can see it when the vehicle is required to be tested for emissions. California requires testing every two years, other states may vary.

28. It will be necessary for all K&N® high flow intake systems to be checked periodically for realignment, clearance and tightening of all connections. Failure to follow the above instructions or proper maintenance may void warranty.

ROAD TESTING:

1. Start the engine with the transmission in neutral or park, and the parking brake engaged. Listen for air leaks or odd noises. For air leaks secure hoses and connections. For odd noises, find cause and repair before proceeding. This kit will function identically to the factory system except for being louder and much more responsive.

2. Test drive the vehicle. Listen for odd noises or rattles and fix as necessary.

3. If road test is fine, you can now enjoy the added power and performance from your kit.

4. K&N Engineering, Inc., requires cleaning the intake system's air filter element every 100,000 miles. When used in dusty or off-road environments, our filters will require cleaning more often. We recommend that you visually inspect your filter once every 25,000 miles to determine if the screen is still visible. When the screen is no longer visible some place on the filter element, it is time to clean it. To clean and re-oil, purchase our filter Recharger® service kit, part number 99-5050 or 99-5000 and follow the easy instructions.

INTAKE SYSTEMS FOR VEHICLES LISTED ARE 50 STATE LEGAL. SEE KNFILTERS.COM FOR CARB STATUS ON EACH PART FOR A SPECIFIC VEHICLE.