



Equipped with AEM® Dryflow™ Filter
No Oil Required!

INSTALLATION INSTRUCTIONS

PART NUMBER

21-8035DC (Gun Metal Gray)

2015-20	CHEVROLET	COLORADO	2.5L	L4
2015-20	GMC	CANYON	2.5L	L4

Not legal for sale or use on any pollution controlled motor vehicle in California or states adopting California emission procedures. See AEMIntakes.com for CARB status on each part for a specific vehicle.

ITEM NO.	PART NUMBER	DESCRIPTION	QTY.
1	21-209D	ELEMENT PARTS KIT; 6.00 X 5"4.75"TOP DRY	1
2	94104	1/2" BNDHOSE CLAMP,4.125-7.00"	1
3	21512-1	ADAPTER; UNIVERSAL, 6" FILTER 3.5" COUPLER	1
4	20-8552	HEAT SHIELD; 21-8035 CHEVROLET COLORADO 2.5L, TB/PC	1
5	1-1020	FASTENER; M6 X 20 DELTA PT	4
6	1-3025	WASHER, M6 SPLIT LOCK ZINC	2
7	1-2110	BOLT; HEX/FLANGE M6-1.0 X 12	2
8	9456	1/2" BNDHOSE CLAMP,3.15"-4.00"	1
9	08657	HOSE; HUMP;3.25 ID- 3.5 ID; BLK; EPDM; 50	1
10	9452	1/2" BNDHOSE CLAMP,2.90"-3.75"	2
11	2-1533C	INTAKE TUBE; 3.25"OD X 19"L, 21-8035DC, GUNMETAL GRAY	1
12	07733	BOLT; M4 - 0.7 8MM, A/H CAP, SS	2
13	087028	HOSE; 1/2" ID X 3-1/2" L	1
14	08553	HOSE CLAMP; SPRING BAND 20MM X 12MM	2
15	084034	HOSE; 3-1/4" TO 2-3/4" ID X 2" L TPRD REINFORCED	1
16	9444	HOSE CLAMP, 2.31-3.25"	1
17	082628	QUICK DISCONNECT W/1/4 NPT	1

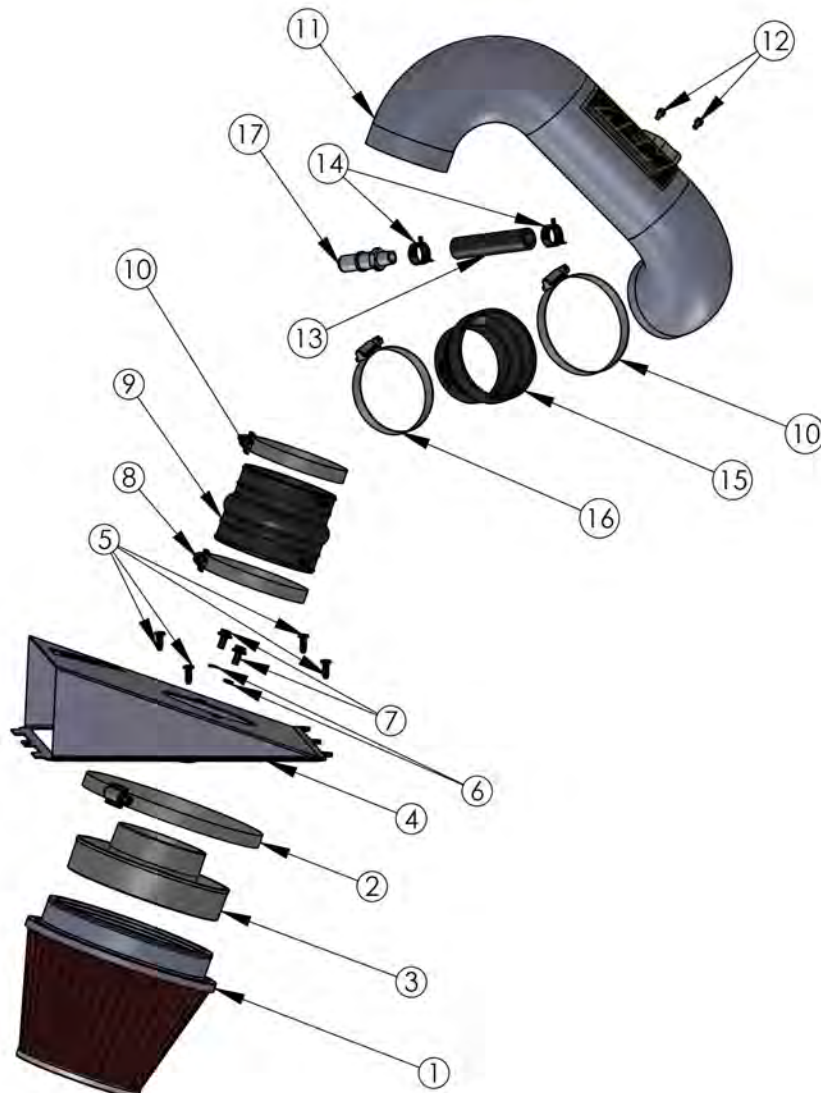

Read and understand these instructions **BEFORE** attempting to install this product. Failure to follow installation instructions and not using the provided hardware may damage the intake tube, throttle body and engine.

Tools Needed:

Screw driver
10MM socket
Socket Driver
4MM Hex Key
T30 Torx bit
T20 Torx bit
Pliers

1. Preparing Vehicle

- a. Make sure vehicle is parked on level surface.
- b. Set the parking brake.
- c. If engine has run in the past two hours, let it cool down.
- d. Disconnect negative battery terminal.
- e. Do not discard stock components after removal of the factory system.
- f. Open the air intake kit package and make sure all parts are included.

2. Removal of stock system



a. Disconnect the wire harness from the MAF sensor. Carefully pry off the wire mounting clip from the airbox lid.



b. Use a T30 Torx bit to remove the indicated bolt on the upper intake resonator.



c. Loosen the hose clamp securing the upper resonator to the throttle body.



d. Loosen the hose clamp securing the bellow coupler to the airbox lid.



e. Disconnect the breather hose located at the rear of the stock intake tube.



f. Slide the couplers off the airbox lid and throttle to remove the upper resonator assembly.



g. Use a Phillips screwdriver to remove the 4 screws securing the airbox lid to its base.



h. Use a T20 Torx bit to remove the MAF sensor from the airbox lid.

3. Installation of AEM® intake system.

- a. When installing the intake system, do not completely tighten the hose clamps or mounting hardware until instructed to do so.



a. Use the provided bolts to install the MAF sensor into the AEM tube.



b. Install the coupler (084034) and hose clamps onto the throttle body.



c. Insert the filter adapter into the filter and fasten with the hose clamp provided.



d. Fasten the adapter to the heat shield using the crush washers and m6 bolts provided.



e. Install the hump hose (08657) and fasten it to the adapter using the hose clamp. Slide hose clamp onto the other end.



f. Fasten the heat shield to the stock lower airbox using the 4 screws provided.



g. Assemble the hose with the spring clamps and quick disconnect nipple provided.



h. Connect the hose assembly and install the AEM tube as shown.



i. Use pliers to slide the spring clamp over the welded nipple. Reconnect the MAF harness to the sensor. Check for clearance with coolant hose and tighten hose clamps.



k. Factory air induction system.



l. Finished installation of AEM Intake System.

4. Reassemble Vehicle

- a. Position the inlet pipes for the best fitment. Be sure that the pipes or any other components do not contact any part of the vehicle.
- b. Check for proper hood clearance. Re-adjust pipes if necessary and re-tighten them.
- c. Inspect the engine bay for any loose tools and check that all fasteners that were moved or removed are properly tightened.
- d. Reconnect negative battery terminal and start engine. Let the vehicle idle for 3 minutes. Perform a final inspection before driving the vehicle.

5. Service and Maintenance

- a. AEM Induction Systems requires cleaning the intake system's air filter element every 100,000 miles. When used in dusty or off-road environments, our filters will require cleaning more often. We recommend that you visually inspect your filter once every 25,000 miles to determine if the screen is still visible. When the screen is no longer visible some place on the filter element, it is time to clean it. To clean, purchase our Synthetic air filter cleaner, part number 1-1000 and follow the easy instructions.
- b. Use window cleaner to clean your powder coated AEM[®] intake tube.

NOTE: DO NOT USE aluminum polish on powder coated AEM[®] intake tubes.

For technical inquiries
e-mail us at
sales@aemintakes.com
or
call us at
800.992.3000

AEM Air Intake System Warranty Policy

AEM® warrants that its intake systems will last for the life of your vehicle. AEM® will not honor this warranty due to mechanical damage (i.e. improper installation or fitment), damage from misuse, accidents or flying debris. AEM® will not warrant its powder coating if the finish has been cleaned with a hydrocarbon-based solvent. The powder coating should only be cleaned with a mild soap and water solution. Proof of purchase of both the vehicle and AEM® intake system is required for redemption of a warranty claim.

This warranty is limited to the repair or replacement of the AEM® part. In no event shall this warranty exceed the original purchase price of the AEM® part nor shall AEM® be responsible for special, incidental or consequential damages or cost incurred due to the failure of this product. Warranty claims to AEM® must be transportation prepaid and accompanied with dated proof of purchase. This warranty applies only to the original purchaser of product and is nontransferable. Improper use or installation, use for racing, accident, abuse, unauthorized repairs or alterations voids this warranty. AEM® disclaims any liability for consequential damages due to breach of any written or implied warranty on all products manufactured by AEM®. Warranty returns will only be accepted by AEM® when accompanied by a valid Return Merchandise Authorization (RMA) number. Credit for defective products will be issued pending inspection. Product must be received by AEM® within 30 days of the date RMA is issued.

If you have a warranty issue, please call (800) 992-3000 and our customer service department will assist you. A proof of purchase is required for all AEM® warranty claims.

Not legal for sale or use on any pollution controlled motor vehicle in California or states adopting California emission procedures. See AEMIntakes.com for CARB status on each part for a specific vehicle.