



INTAKE SYSTEM

INSTALLATION INSTRUCTIONS

21-853C
SCION
 2013-16 FRS
 H4-2.0L
SUBARU
 2013-20 BRZ
 H4-2.0L
TOYOTA
 2017-20 86
 H4-2.0L

INTAKE SYSTEMS FOR VEHICLES LISTED ARE 50 STATE LEGAL. SEE AEMINTAKES.COM FOR CARB STATUS ON EACH PART FOR A SPECIFIC VEHICLE.

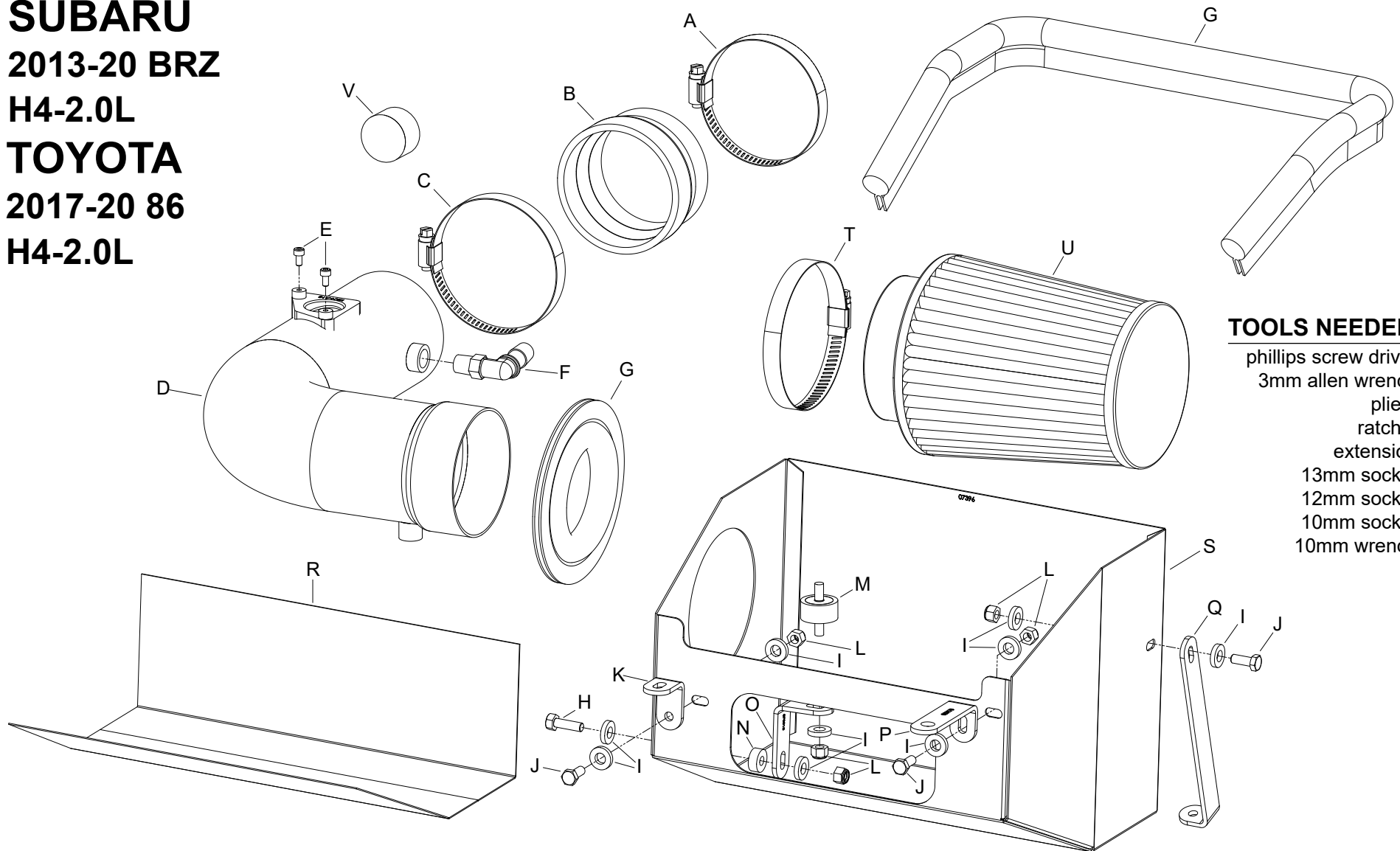

TOOLS NEEDED:

phillips screw driver
 3mm allen wrench
 pliers
 ratchet
 extension
 13mm socket
 12mm socket
 10mm socket
 10mm wrench

PARTS LIST:

Description	Qty.	Part #	Description	Qty.	Part #	Description	Qty.	Part #
A HOSE CLAMP #48	1	08601	I WASHER; 1/4"ID X 5/8"OD- SAE	9	08275	Q BRACKET; 69-2521, "L", SML	1	070066A
B HOSE; 3.25"ID TO 3"ID X 2"L	1	08186	J BOLT; 6MM-1 X 16MM	3	07812	R ADHESIVE HEAT BARRIER	2	8-165
C HOSE CLAMP #52	1	08610	K BRACKET; "L" 57-1520, SMALL	1	070026A	S HEAT SHIELD	1	07396
D INTAKE TUBE	1	2-1625C	L NUT; 6MM NYLOCK, HEXHEAD	5	07512	T HOSE CLAMP #60	1	08624
E BOLT; M4-.7 X 8MM, A/H CAP	2	07733	M STUD; M6-1.00 M/M, RUBBER	1	07027	U FILTER	1	21-204DK
F VENT; 90 DEG, 1/2" HOSE, NPT	1	08110FK	N SPACER; .625" OD X .250"ID	1	06555	V CAPLUG	1	081100
G EDGE TRIM (44")	1	102486A	O BRACKET; 63-1025, SMALL	1	070015A			
H BOLT; M6 X 1 X 20MM HEX	1	07795	P BRACKET, "L", 69-8619, STL	1	083170			

If you need any assistance please call 1-800-858-3333 to speak with a representative in our Customer Service Center before returning the product.

Read and understand these instructions **BEFORE** attempting to install this product. Failure to follow installation instructions and not using the provided hardware may damage the intake tube, throttle body and engine.

TO START:

1. Turn off the ignition and disconnect the negative battery cable.
NOTE: Disconnecting the negative battery cable erases pre-programmed electronic memories. Write down all memory settings before disconnecting the negative battery cable. Some radios will require an anti-theft code to be entered after the battery is reconnected. The anti-theft code is typically supplied with your owner's manual. In the event your vehicles anti-theft code cannot be recovered, contact an authorized dealership to obtain your vehicles anti-theft code.



2. Disconnect the mass air sensor electrical connection and unhook the wiring harness from the air box.



3. Release the spring clamp and then disconnect the crank case vent hose from the fitting.



4. Loosen the hose clamp securing the intake hose to the throttle body.



5. Loosen the hose clamp and disconnect the engine sound tube from the engine sound drum.



6. Remove the two bolts shown securing the resonator and air box to the core support.
NOTE: These bolts will be reused in a later step.



7. Remove the remaining air box mounting bolt then lift up the air box assembly and remove it from the vehicle.
NOTE: This bolt will be reused in a later step.



8. Install the provided heat shield mounting bracket (070026) onto the lower air box mount using the factory bolt.



9. Install the provided coupling hose (08186) onto the throttle body and secure with the provided hose clamp.

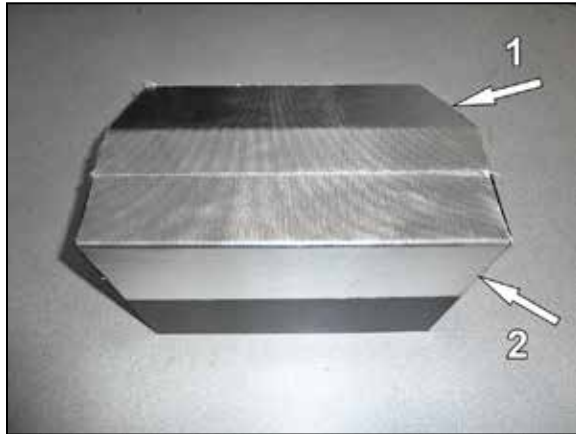

10. Install the provided heat shield insulation strips onto the bottom of the heat shield as shown. Some trimming of the insulation strips excess will be necessary.



11. Install the provided "L" bracket (083170) onto the heat shield using the provided hardware. Install the provided "L" bracket (070066) onto the heat shield using the provided hardware.



12. Install the provided "L" bracket (070015) onto the heat shield using the provided spacer between the bracket and heat shield and hardware.
NOTE: Do not completely tighten at this time.

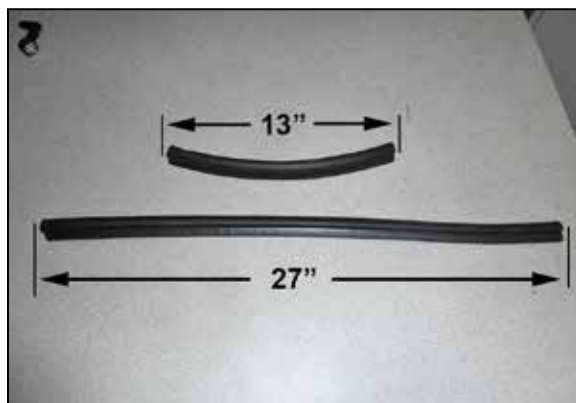

13. Cut the provided edge trim into two sections, one section is to be 27" long and the other section is to be 13" long.



14. Install the 13" long section of edge trim into the hole of the heat shield as shown and then install the 27" long section of edge trim onto the top of the heat shield as shown.



15. Remove the core support bolt shown.
NOTE: This bolt will be reused.



16. Set the heat shield into position on the core support and secure with the factory air box mounting bolts and to the previously installed bracket with the hardware provided.



17. Remove the mass air sensor from the factory air filter housing and then install it into the AEM® intake tube using the provided hardware. Install the provided 90° vent fitting into the AEM® intake tube as shown.



18. Install the tube through the heat shield and then install the provided rubber mounted stud onto the tube as shown.
NOTE: The tube is a tight fit through the opening, take care so as not to damage the edge trim.



19. Rotate the tube down and install it into the coupling hose on the throttle body and install the mounting stud into the bracket. Secure the tube with the provided hose clamps and hardware and tighten the mounting bracket at this time.



20. Connect the crank case vent to the fitting installed into the AEM® intake tube as shown. Reconnect the mass air sensor electrical connection.



21. Install the provided caplug onto the sound drum.



22. Install the air filter onto the AEM® intake tube and secure with the provided hose clamp.



Reassemble Vehicle

Position the inlet pipes for the best fitment. Be sure that the pipes or any other components do not contact any part of the vehicle. Tighten the rubber mount, all bolts, and hose clamps. Check for proper hood clearance. Re-adjust pipes if necessary and re-tighten them. Inspect the engine bay for any loose tools and check that all fasteners that were moved or removed are properly tightened. Reconnect negative battery terminal and start engine. Let the vehicle idle for 3 minutes. Perform a final inspection before driving the vehicle.

CARB Sticker Placement

The C.A.R.B. exemption sticker, (attached), must be visible under the hood so that an emissions inspector can see it when the vehicle is required to be tested for emissions. California requires testing every two years, other states may vary.

Service and Maintenance

AEM Induction Systems requires cleaning the intake system's air filter element every 100,000 miles. When used in dusty or off-road environments, our filters will require cleaning more often. We recommend that you visually inspect your filter once every 25,000 miles to determine if the screen is still visible. When the screen is no longer visible some place on the filter element, it is time to clean it. To clean, purchase our Synthetic air filter cleaner, part number 1-1000 and follow the easy instructions. Use window cleaner to clean your powder coated AEM® intake tube.

NOTE: DO NOT USE aluminum polish on powder coated AEM® intake tubes.

INTAKE SYSTEMS FOR VEHICLES LISTED ARE 50 STATE LEGAL. SEE AEMINTAKES.COM FOR CARB STATUS ON EACH PART FOR A SPECIFIC VEHICLE.

AEM Air Intake System Warranty Policy

AEM® warrants that its intake systems will last for the life of your vehicle. AEM will not honor this warranty due to mechanical damage (i.e. improper installation or fitment), damage from misuse, accidents or flying debris. AEM will not warrant its powder coating if the finish has been cleaned with a hydrocarbon-based solvent. The powder coating should only be cleaned with a mild soap and water solution. Proof of purchase of both the vehicle and AEM intake system is required for redemption of a warranty claim.

This warranty is limited to the repair or replacement of the AEM part. In no event shall this warranty exceed the original purchase price of the AEM part nor shall AEM be responsible for special, incidental or consequential damages or cost incurred due to the failure of this product. Warranty claims to AEM must be transportation prepaid and accompanied with dated proof of purchase. This warranty applies only to the original purchaser of product and is nontransferable. Improper use or installation, use for racing, accident, abuse, unauthorized repairs or alterations voids this warranty. AEM disclaims any liability for consequential damages due to breach of any written or implied warranty on all products manufactured by AEM. Warranty returns will only be accepted by AEM when accompanied by a valid Return Merchandise Authorization (RMA) number. Credit for defective products will be issued pending inspection. Product must be received by AEM within 30 days of the date RMA is issued.

If you have a warranty issue, please call (800) 992-3000 and our customer service department will assist you. A proof of purchase is required for all AEM warranty claims.