



INSTALLATION INSTRUCTIONS

21-855C (Gun Metal Gray Finish)
TOYOTA
2018-20 Camry
L4-2.5L

NOT LEGAL FOR SALE OR USE ON ANY POLLUTION CONTROLLED MOTOR VEHICLE IN CALIFORNIA OR STATES ADOPTING CALIFORNIA EMISSION PROCEDURES.

See aemintakes.com for CARB status on each part for a specific vehicle

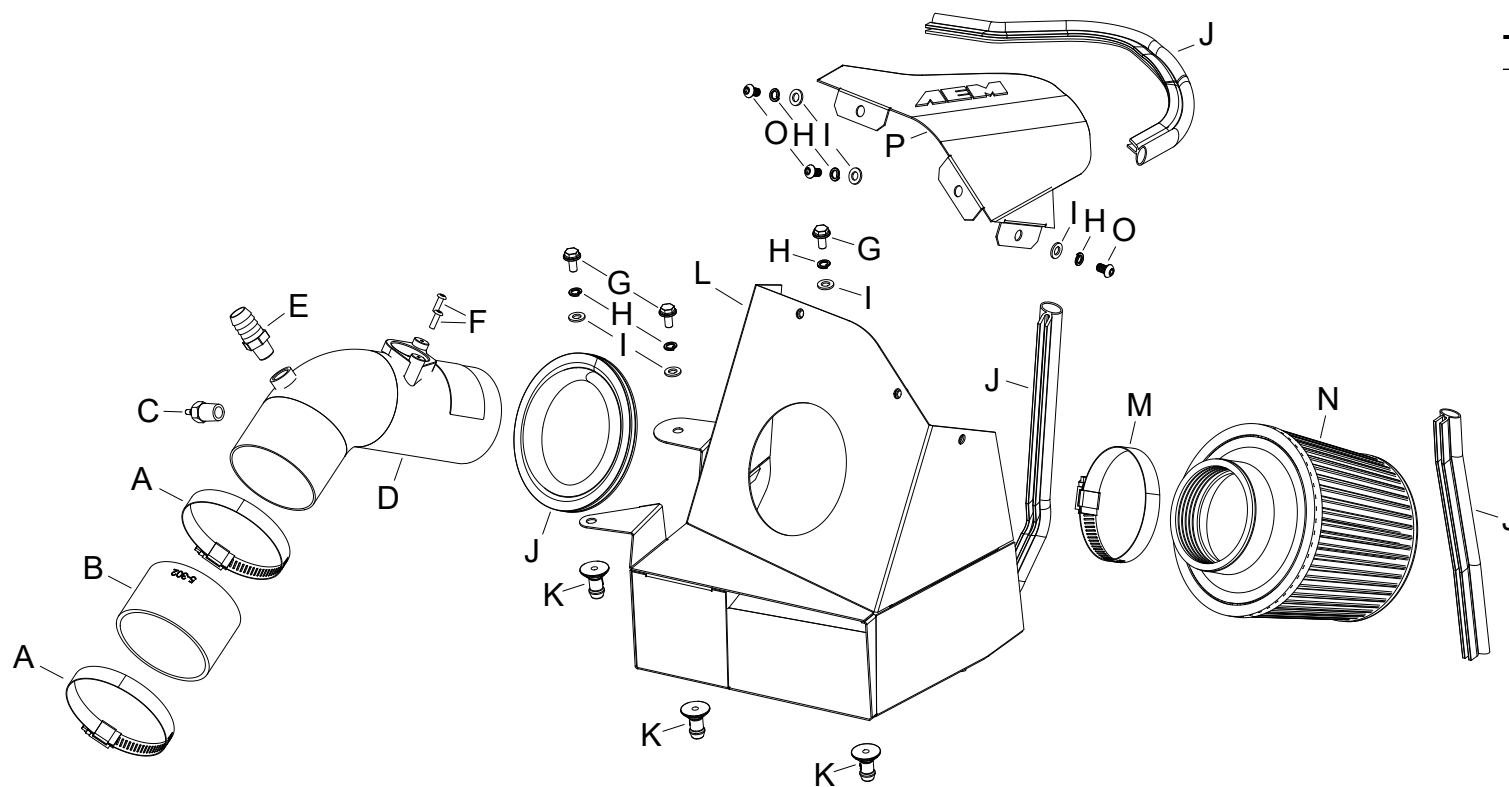

TOOLS NEEDED:

Pliers
 Flat blade screw driver
 2.5mm allen
 4mm allen
 10mm wrench
 Phillips screw driver
 9/16" wrench
 11/16" wrench

PARTS LIST:

Description	Qty.	Part #	Description	Qty.	Part #	Description	Qty.	Part #
A HOSE CLAMP; #48	2	08601	G BOLT; M6 X 1.00 X 16MM, SS	3	07812	M 1/2" BNDHOSE CLAMP, 2.90"	1	9452
B HOSE, SILICONE 3.00X2"	1	5-302	H WASHER, M6 SPLIT LOCK ZINC	6	1-3025	N AIR FILTER	1	21-203DK
C VENT; STRT, 1/8 HOSE, 1/4 NPT	1	08052	I WASHER; 6MM FLAT, SS	6	08269	O BOLT; M6 X 1.00" 12MM, SS	3	07794
D INTAKE TUBE	1	2-1627C	J EDGE TRIM; 3/4" BULB, TOP	1	102481	P HEAT SHIELD LID	1	20-8639
E VENT; STRT, 5/8 BARBED 1/4	1	08911-1	K MOUNT, PLASTIC AIRBOX	3	8-186-1			
F BOLT; M4-.7 X 8MM, ALLEN SS	2	07741	L HEAT SHIELD	1	20-8638			

If you need any assistance please call 1-800-858-3333 to speak with a representative in our Customer Service Center before returning the product.

Read and understand these instructions **BEFORE** attempting to install this product. Failure to follow installation instructions and not using the provided hardware may damage the intake tube, throttle body and engine.

TO START:

1. Turn off the ignition and disconnect the negative battery cable.

NOTE: Disconnecting the negative battery cable erases pre-programmed electronic memories. Write down all memory settings before disconnecting the negative battery cable. Some radios will require an anti-theft code to be entered after the battery is reconnected. The anti-theft code is typically supplied with your owner's manual. In the event your vehicles anti-theft code cannot be recovered, contact an authorized dealership to obtain your vehicles anti-theft code.



2. Disconnect the mass air sensor electrical connector and then disconnect the wiring harness from the air filter housing.



3. Disconnect the two vent lines from the intake tube.



4. Release the spring clamp and disconnect the intake hose from the throttle body.



5. Lift up and remove the intake system from the vehicle.

NOTE: AEM recommends that customers do not discard factory air intake.



6. Remove the mass air sensor from the factory intake hose and then install it into the AEM® intake tube using the hardware provided.



7. Install the two provided vents into the AEM® intake tube as shown.

NOTE: Plastic NPT fittings are easy to cross thread. Install the vent fitting “hand” tight, then turn it two complete turns with a wrench.



8. Install the provided coupler onto the throttle body and secure with the provided hose clamp.



9. Cut the provided edge trim into four sections as shown. 3-1/4", 9-1/2", 13-1/4", 22".



10. Attach the heat shield lid using the provided hardware.



11. Install the 3-1/4" and 13-1/4" edge trim sections as shown.

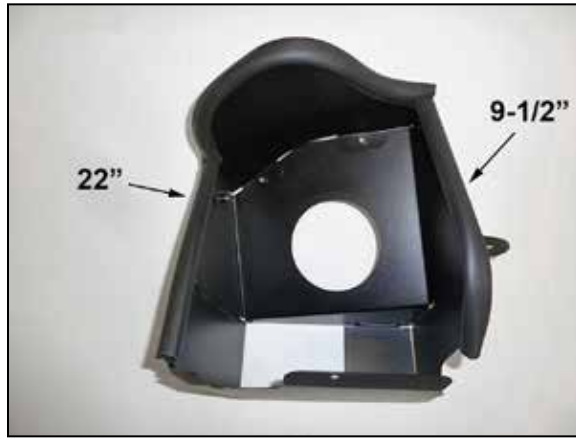

12. Install the 9-1/2" and 22" edge trim sections as shown.



13. Install the heat shield mounting studs onto the heat shield as shown using the provided hardware.



14. Install the AEM® air filter through the hole in the heat shield and then install the intake tube into the filter and secure with the provided hose clamp.



15. Install the complete intake assembly into the vehicle so the mounting studs engage with the factory air filter housing mounts, the intake tube engages the coupling hose and the fresh air intake duct inserts into the heat shield. Align the intake tube and then tighten the hose clamp that secures the intake tube.



16. Connect the factory vent hoses to the fittings installed into the AEM® intake tube.



Reassemble Vehicle

Position the inlet pipes for the best fitment. Be sure that the pipes or any other components do not contact any part of the vehicle. Tighten the rubber mount, all bolts, and hose clamps. Check for proper hood clearance. Re-adjust pipes if necessary and re-tighten them. Inspect the engine bay for any loose tools and check that all fasteners that were moved or removed are properly tightened. Reconnect negative battery terminal and start engine. Let the vehicle idle for 3 minutes. Perform a final inspection before driving the vehicle.

Service and Maintenance

AEM Induction Systems requires cleaning the intake system's air filter element every 100,000 miles. When used in dusty or off-road environments, our filters will require cleaning more often. We recommend that you visually inspect your filter once every 25,000 miles to determine if the screen is still visible. When the screen is no longer visible some place on the filter element, it is time to clean it. To clean, purchase our Synthetic air filter cleaner, part number 99-0624 and follow the easy instructions. Use window cleaner to clean your powder coated AEM® intake tube.

NOTE: DO NOT USE aluminum polish on powder coated AEM® intake tubes.

NOT LEGAL FOR SALE OR USE ON ANY POLLUTION CONTROLLED MOTOR VEHICLE IN CALIFORNIA OR STATES ADOPTING CALIFORNIA EMISSION PROCEDURES.

See aemintakes.com for CARB status on each part for a specific vehicle

AEM Air Intake System Warranty Policy

AEM® warrants that its intake systems will last for the life of your vehicle. AEM will not honor this warranty due to mechanical damage (i.e. improper installation or fitment), damage from misuse, accidents or flying debris. AEM will not warrant its powder coating if the finish has been cleaned with a hydrocarbon-based solvent. The powder coating should only be cleaned with a mild soap and water solution. Proof of purchase of both the vehicle and AEM intake system is required for redemption of a warranty claim.

This warranty is limited to the repair or replacement of the AEM part. In no event shall this warranty exceed the original purchase price of the AEM part nor shall AEM be responsible for special, incidental or consequential damages or cost incurred due to the failure of this product. Warranty claims to AEM must be transportation prepaid and accompanied with dated proof of purchase. This warranty applies only to the original purchaser of product and is nontransferable. Improper use or installation, use for racing, accident, abuse, unauthorized repairs or alterations voids this warranty. AEM disclaims any liability for consequential damages due to breach of any written or implied warranty on all products manufactured by AEM. Warranty returns will only be accepted by AEM when accompanied by a valid Return Merchandise Authorization (RMA) number. Credit for defective products will be issued pending inspection. Product must be received by AEM within 30 days of the date RMA is issued.

If you have a warranty issue, please call (800) 992-3000 and our customer service department will assist you. A proof of purchase is required for all AEM warranty claims.