



Installation Instructions

For Part Numbers:

250-333C 700-461 Airaid Oiled Media Filter

251-333C 701-461 SynthaMax Dry Media Filter - Red

2016-20 Chevrolet Camaro SS

6.2L- V8

NOT LEGAL FOR SALE OR USE ON ANY POLLUTION CONTROLLED MOTOR VEHICLE IN CALIFORNIA OR STATES ADOPTING CALIFORNIA EMISSION PROCEDURES.

See Airaid.com for CARB status on each part for a specific vehicle

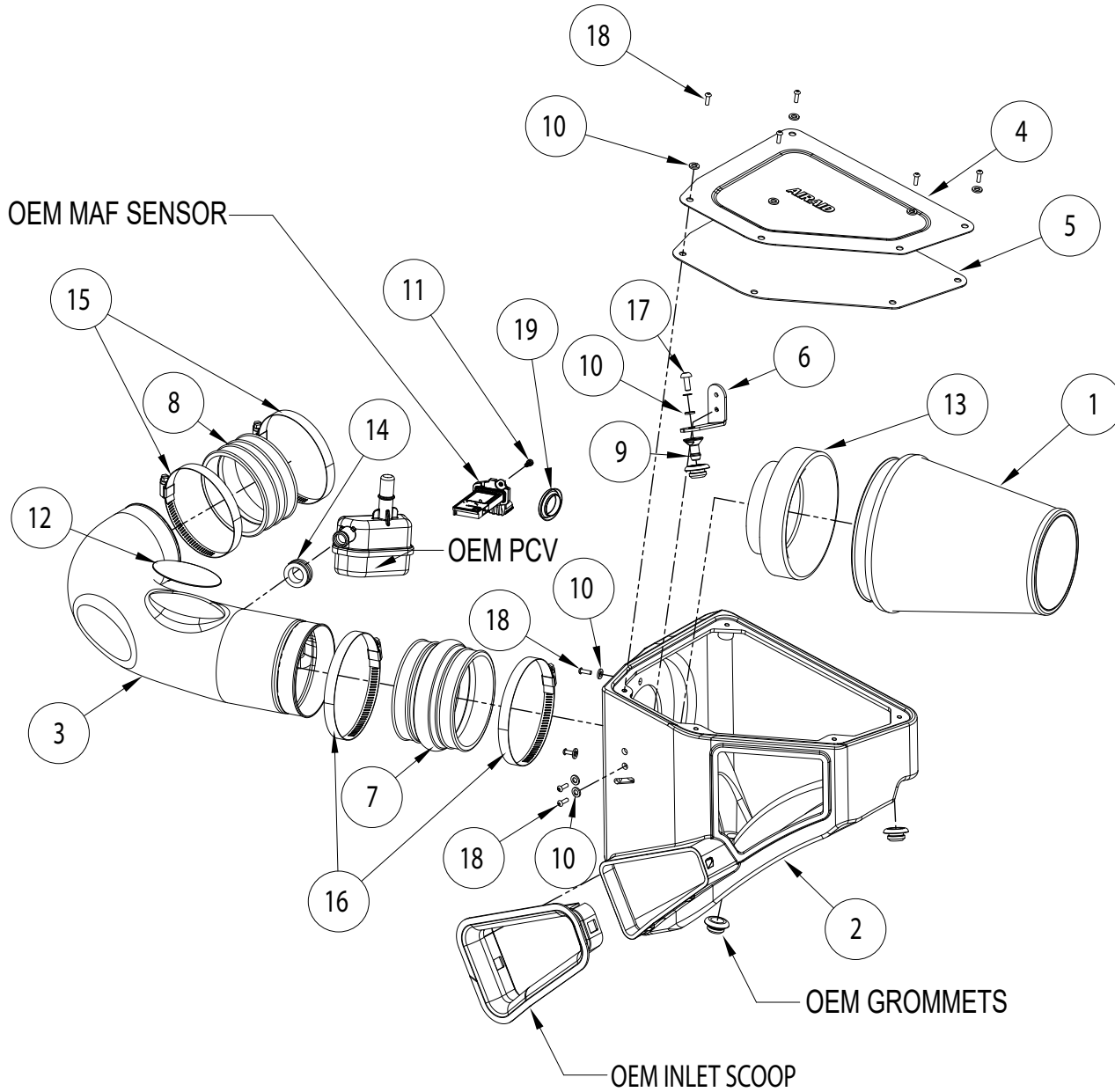

Component Identification

1	700/701-461	FILTER, 700-461	1
2	KIT333CAB	AIRBOX, INTAKE, 250-333	1
3	KIT333CF	TUBE, INTAKE, 250-333C	1
4	KIT333LIDCF	LID, AIRBOX, 250-333C	1
5	KIT333G	GASKET, LID, 250-333	1
6	KIT333BC	BRACKET, INTAKE, 250-333	1
7	KITHUMPHS05EPDM	HUMPHOSE, 4.250D-3.100L	1
8	KITCOUPLER10EPDM	COUPLER, 3.875D-2.000L	1
9	8-186-1	PLASTIC AIRBOX MOUNT	1
10	1-3016	M6 X 12MM FLAT WASHER	11
11	07733	M4X.7-8mm SHCS SS	2
12	KITSTICKER53	STICKER, AIRAID	1
13	KIT1121MAFADA	VELOCITY STACK	1
14	08058	GROMMET	1
15	08645	HOSE CLAMP #64	2
16	08671	HOSE CLAMP #72	2
17	07730	BOLT M6 X 1.00X 16MM	1
18	07706	1/4-20 X 1/2 SS BTN HEAD	10
19	KITPLUG03	PLUG; FIREWALL 29MM	1

Full color instructions can be viewed on our web site at Airaid.com. If you need any assistance please call 1-800-858-3333 to speak with a representative in our Customer Service Center before returning the product.



1. Inside the trunk, on the passenger side, locate and remove the access panel for the battery. Disconnect the negative battery cable. **NOTE: Vehicle shown is a convertible.**



2. Release the spring clamp securing the resonator tube to the 90 deg. Fitting and then disconnect the tube. Depress the locking tab and then disconnect the crank case vent hose.



3. Loosen the two hose clamps that secure the factory intake tube and then remove the intake tube from the vehicle.



4. Disconnect Mass air flow sensor electrical connection and then lift and remove the complete air filter housing from the vehicle. **NOTE: Airaid recommends that customers do not discard factory air intake.**



5. Be sure that all three mounting grommets are still in the proper place and not still attached the factory air filter housing.



6. Using a T50 TORX, remove the two bolts securing the sound resonator to the front of the engine.

Continued...



7. Locate and disconnect the sound tube retainers on the strut tower brace and A/C line.



8. At the firewall, Remove the 6mm flange nut that secures the sound tube to the firewall. Turn the tube ¼ turn clockwise and the remove the tube from the vehicle.



9. Install the provided plug into the sound tube hole.

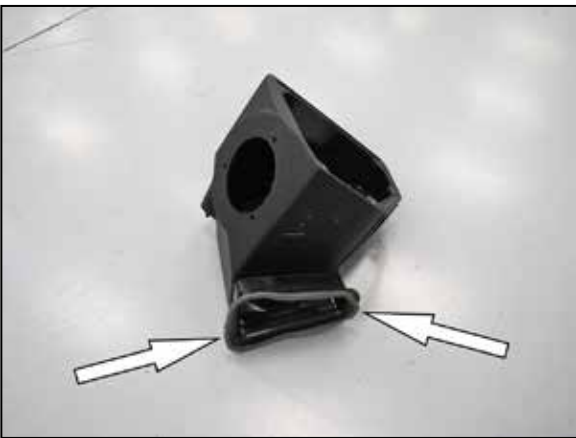

10. Remove the air box inlet from the factory air filter housing and install it onto the AIRAID air filter housing.



11. Install the provided air filter housing bracket onto the AIRAID air filter housing and then install the provided mounting stud onto the bracket as shown.



12. Install the radius filter adapter into the AIRAID filter housing and secure with the provided hardware.

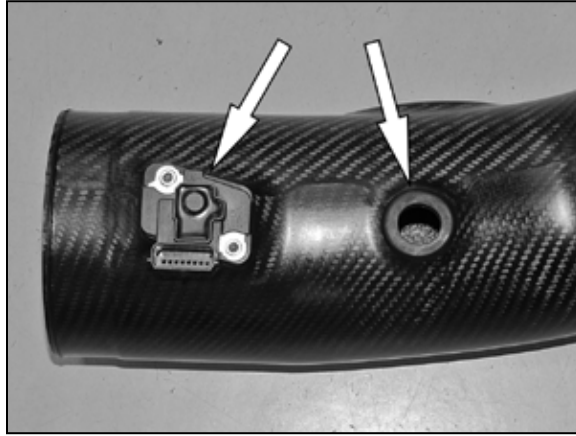

13. Remove the mass air sensor from the factory air filter housing and install it into the AIRAID intake tube with the provided hardware. Install the provided crank case grommet into the AIRAID intake tube as shown.



14. Install the AIRAID decal onto the intake tube as shown.



15. Cut the clamp that secures the PCV chamber into the factory intake tube and then remove the chamber from the tube.



16. Install the PCV chamber into the grommet previously installed into the AIRAID intake tube as shown.

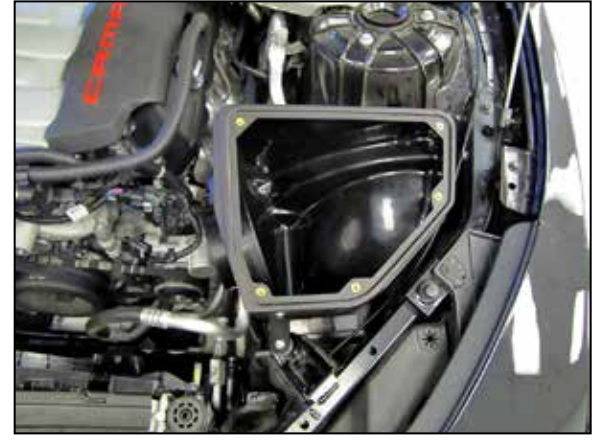

17. Install the AIRAID filter housing into the vehicle so that the mounting posts are engaged into the factory filter housing mounting grommets.



18. Install the coupler houses and hose clamps onto the AIRAID intake tube but do not tighten the clamps. Install the intake tube assembly onto the filter adapter and throttle body. Adjust the assembly for best fit and then secure all the hose clamps.



19. Connect the crank case vent hose to the PCV vent chamber and connect the mass air sensor electrical connection.



20. Install the AIRAID air filter onto the filter adapter and secure with the provided hose clamp.



21. Install the provided gasket onto the air filter housing lid.

Continued...



22. Install the air filter housing lid onto the AIRAID air filter housing and secure with the provided hardware.



23. Double check your work!

Make sure there is no foreign material in the intake path. Make sure all clamps, hoses, bolts, and screws are tight. Double check the hood clearance!

Reconnect the negative battery cable!

Thank you for purchasing the Airaid Intake System. Contact Airaid @ (800) 498-6951 8:00 AM - 5:00 PM MST weekdays for questions regarding fit or instructions that are not clear to you. Your Airaid Intake System was carefully inspected and packaged. Check that no parts are missing, or were damaged during shipping. If any parts are missing, contact Airaid. The air filter element is protected from direct exposure to water and debris; care should be taken not to drive through deep water.

WATER INGESTION IS THE DRIVERS RESPONSIBILITY! The air filter is reusable and should be cleaned periodically.

FILTER IDENTIFICATION

700-461 Airaid Oiled Media

701-461 Airaid SynthaMax Dry Media - Red

For your Oiled media filter we offer the Airaid Tune Up Kit!



P/N 790-551 Aerosol Spray
P/N 790-550 Squeeze Spray



NOT LEGAL FOR SALE OR USE ON ANY POLLUTION CONTROLLED MOTOR VEHICLE IN CALIFORNIA OR STATES ADOPTING CALIFORNIA EMISSION PROCEDURES.

See Airaid.com for CARB status on each part for a specific vehicle

SynthaMax

Do Not Oil

Synthamax Air Filters do not require oil. Service air filter as needed by cleaning with common non-petroleum all-purpose household cleaner and water. Simple Green®, Formula 409® or equivalent works great. Apply cleaner to outside of air filter and allow to soak. Then flush filter clean from the inside out with a garden hose and repeat steps if necessary. Do not apply high pressure water or air to clean filter. Allow filter to air dry and reinstall.