



INSTALLATION INSTRUCTIONS

PART NUMBER: RK-3954

This Assembly Fits:

SEE CATALOG FOR CURRENT APPLICATIONS

SEE KNFILTERS.COM FOR CARB STATUS ON EACH PART FOR A SPECIFIC VEHICLE

Congratulations, you have purchased the finest custom air cleaner that money can buy. With proper care, this filter will last 1 million miles or more. This custom air cleaner replaces the stock air cleaner assembly. The following procedure **MUST** be followed to ensure a proper fit and seal of the custom air cleaner.

TOOLS NEEDED:

- ratchet
- extension
- 7/16" socket
- 3/16" allen key
- 3/8" allen key
- 9/32" allen key
- 3mm allen key
- t27 torx
- 3/8" wrench

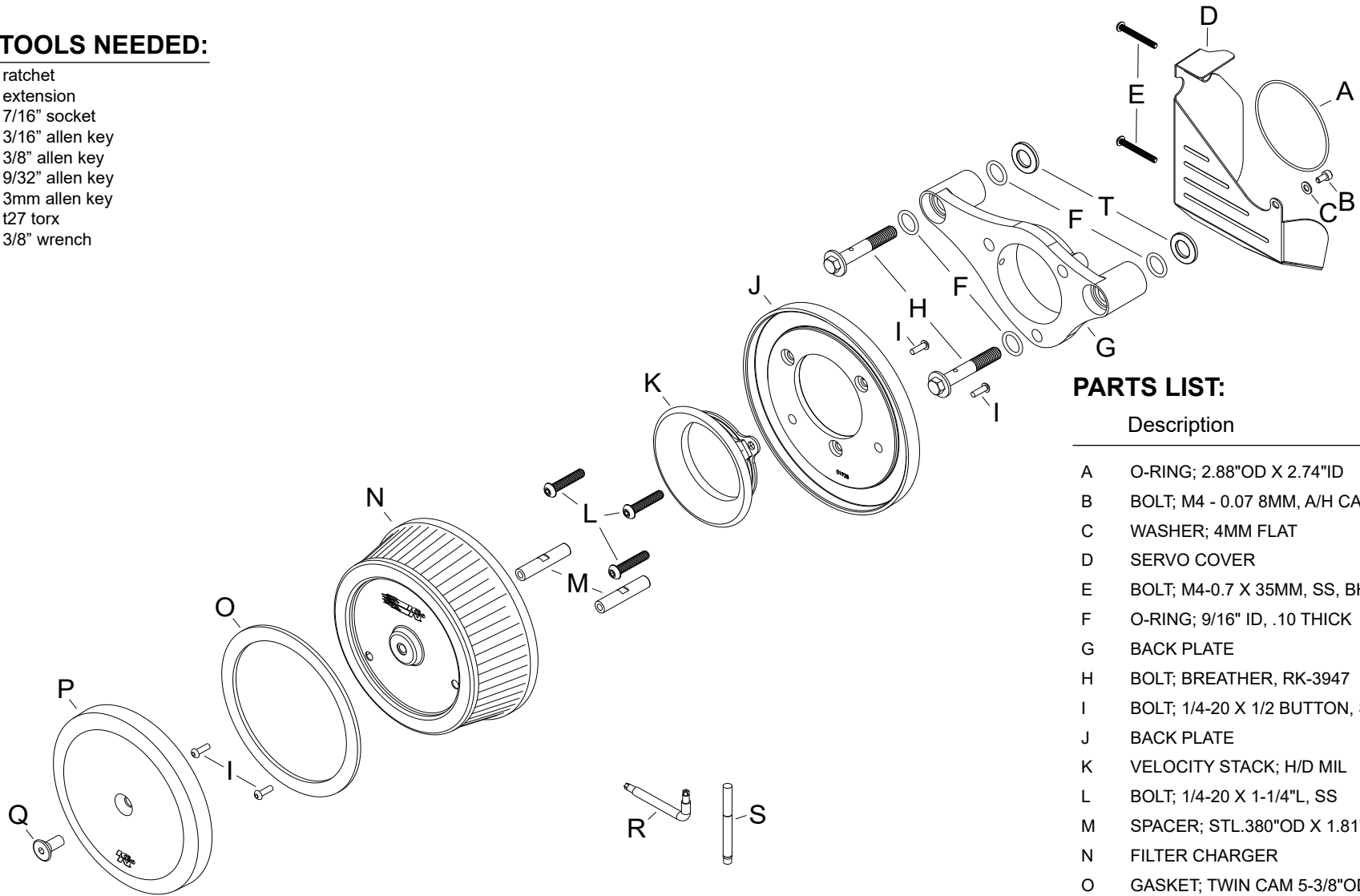

PARTS LIST:

Description	Qty.	Part #
A O-RING; 2.88"OD X 2.74"ID	1	09773
B BOLT; M4 - 0.07 8MM, A/H CAP	1	07733
C WASHER; 4MM FLAT	1	08278
D SERVO COVER	1	073242
E BOLT; M4-0.7 X 35MM, SS, BHA	2	077012
F O-RING; 9/16" ID, .10 THICK	4	07761
G BACK PLATE	1	01935
H BOLT; BREATHER, RK-3947	2	077008
I BOLT; 1/4-20 X 1/2 BUTTON, SS	4	07706
J BACK PLATE	1	01938
K VELOCITY STACK; H/D MIL	1	09257
L BOLT; 1/4-20 X 1-1/4"L, SS	3	077011
M SPACER; STL.380"OD X 1.81"L	2	08599-1
N FILTER CHARGER	1	E-3990
O GASKET; TWIN CAM 5-3/8"OD	1	10486
P COVER	1	01909
Q BOLT; 5/16-18 X 3/4" F/H/A, SS	1	22219
R WRENCH; TORX T20 T/R	1	69801
S 2ML, MEDIUM STRENGTH	1	482
T SPACER	2	06536

If you need any assistance please call 1-800-858-3333 to speak with a representative in our Customer Service Center before returning the product.

NOTE: FAILURE TO FOLLOW INSTALLATION INSTRUCTIONS AND NOT USING THE PROVIDED HARDWARE MAY DAMAGE THE INTAKE TUBE, THROTTLE BODY AND ENGINE.

TO START:

1. Turn off the ignition and disconnect the negative battery cable.



2. Loosen and remove the bolt which secures the decorative filter cover and remove the cover from the vehicle.



3. Remove the three bolts that secure the air filter element and then remove the air filter and crank case breather tubes.



4. Remove the two breather bolts shown and then remove the rear air filter housing from the vehicle. **NOTE: K&N Engineering, Inc. recommends that customers do not discard the factory air intake components..**



5. Remove the two servo cover bolts shown.



6. Install the K&N® servo cover and secure with the provided hardware to the original servo cover mounting bolt locations.

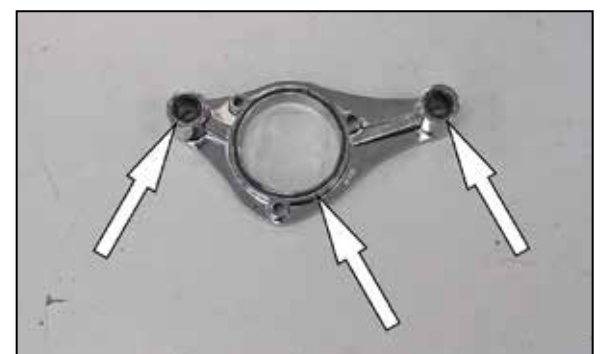

7. Install two of the breather O-rings and the throttle body O-ring into the base plate as shown. **NOTE: Use a few small dabs of grease to secure the O-rings in place while installing the base plate to the engine.**



8. Using the provided throttle body mounting bolts, install the base plate onto the engine. Do not completely tighten the bolts; they are just being used to hold the base plate in the correct position at this time. Secure the servo cover to the back of the base plate with the hardware provided. Now install the remaining breather O-rings into the base plate and secure the base plate with the provided breather bolts. Then remove the three throttle body bolts.

NOTE: Apply one drop of the provided thread locker to the threads of each bolt.

NOTE: On applications that have had the support bracket removed, install the two provided spacers between the back plate and cylinder head at the breather holes and then install the breather bolts as shown.



9. Install the provided velocity stack into the filter back plate as shown.



10. Install the two provided spacers onto the filter back plate and secure with the provided hardware.

NOTE: Apply one drop of the provided thread locker to the threads of each bolt.



11. Install the filter back plate assembly onto the base plate and secure with the three throttle body bolts provided.

NOTE: Apply one drop of the provided thread locker to the threads of each bolt.



12. Install the provided gasket onto the filter as shown.

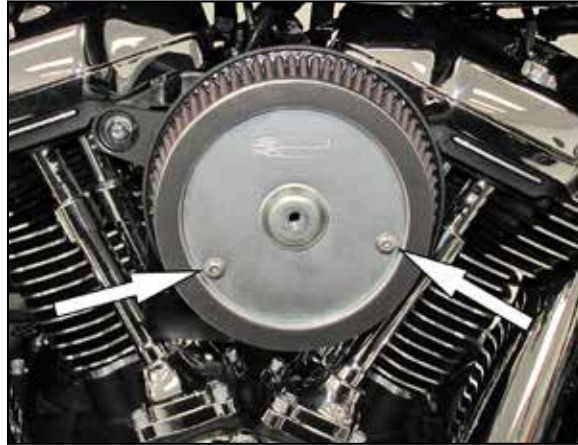

13. Install the filter onto the back plate and secure with the provided hardware.

NOTE: Apply one drop of the provided thread locker to the threads of each bolt.



14. Install the top plate onto the filter and secure with the provided hardware.

NOTE: Apply one drop of the provided thread locker to the threads of each bolt.

15. Reconnect the vehicle's negative battery cable. Double check to make sure everything is tight and properly positioned before starting the vehicle.

16. The C.A.R.B. exemption sticker, (attached), must be visible, so the emissions inspector can see it when the vehicle is required to be tested for emissions. California requires testing every two years, other states may vary.

17. It will be necessary for all K&N® custom air cleaners to be checked periodically for realignment, clearance and tightening of all connections. Failure to follow the above instructions or proper maintenance may void warranty.

ROAD TESTING:

1. Start the engine with the transmission in neutral. Listen for air leaks or odd noises. For air leaks secure hoses and connections. For odd noises, find cause and repair before proceeding. This kit will function identically to the factory system except for being louder and much more responsive.

2. Test ride the vehicle. Listen for odd noises or rattles and fix as necessary.

3. If road test is fine, you can now enjoy the added power and performance from your kit.

4. K&N Engineering, Inc., requires cleaning the intake system's air filter element every 50,000 miles. When used in dusty or off-road environments, our filters will require cleaning more often. We recommend that you visually inspect your filter once every 25,000 miles to determine if the screen is still visible. When the screen is no longer visible some place on the filter element, it is time to clean it. To clean and re-oil, purchase our filter Recharger® service kit, part number 99-5050 or 99-5000 and follow the easy instructions.

INTAKE SYSTEMS FOR VEHICLES LISTED ARE 50 STATE LEGAL. SEE KNFILTERS.COM FOR CARB STATUS ON EACH PART FOR A SPECIFIC VEHICLE.