



INTAKE SYSTEMS FOR VEHICLES LISTED ARE 50 STATE LEGAL. SEE KNFILTERS.COM FOR CARB STATUS ON EACH PART FOR A SPECIFIC VEHICLE.

INSTALLATION INSTRUCTIONS

57-1122P

HARLEY DAVIDSON

SEE CATALOG OR KNFILTERS.COM FOR CURRENT APPLICATIONS

TOOLS NEEDED:

- 3/16" Allen Wrench
- 5/16" Allen Wrench
- 7/16" Socket
- 3/4" Wrench
- Extension
- Flat Blade Screwdriver
- Ratchet
- T27 Torx Socket

PARTS LIST:

Description	Qty.	Part #
A WASHER; 1/2"ID, .040"THK	4	08322
B BREATHER TUBE; CHROME	1	21679
C BOLT; BREATHER	2	22210
D HOSE; 8MM ID X 2.25"L	1	08062
E GASKET; HD-1508	1	10489
F THREAD LOCKER	1	482
G INTAKE TUBE; BRIGHT	1	27405AP
H WASHER; 6MM FLAT	3	08269
I SCREW; 1/4-20 X 3/4" SOCKET	3	07731
J HOSE CLAMP #40	1	08554KA
K AIR FILTER	1	RC-3680

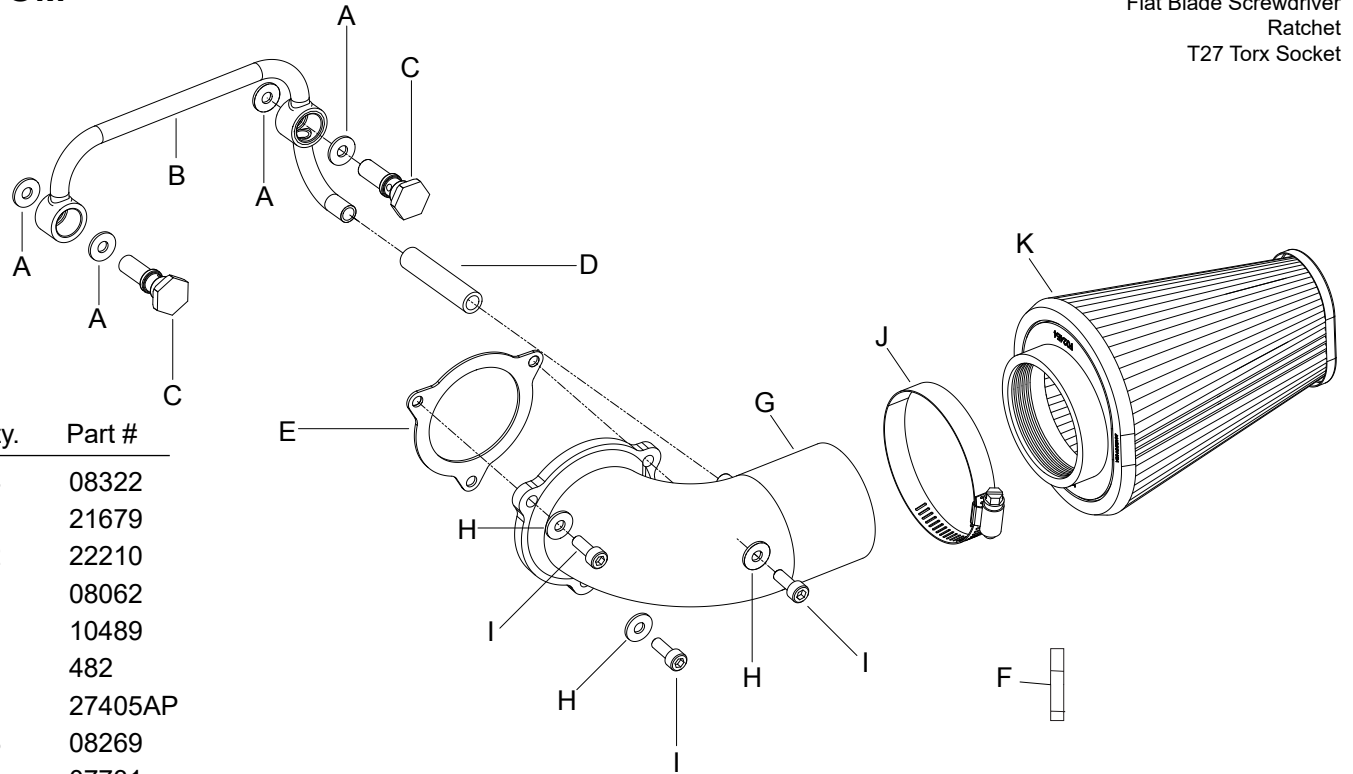

NOTE: FAILURE TO FOLLOW INSTALLATION INSTRUCTIONS AND NOT USING THE PROVIDED HARDWARE MAY DAMAGE THE INTAKE TUBE, THROTTLE BODY AND ENGINE.

TO START:

1. Turn off the ignition and disconnect the negative battery cable.



2. Remove the air filter cover bolt and air filter cover as shown.

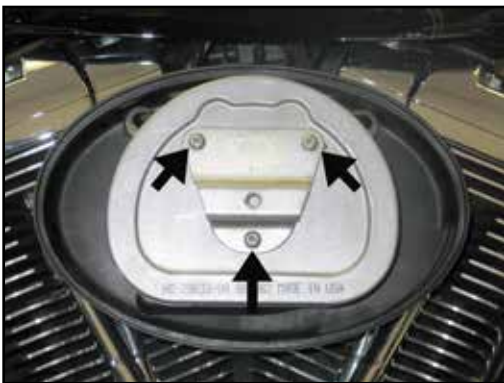

3. Loosen the three air filter retaining bolts shown.



4. Remove the air filter from the vehicle and disconnect the crankcase breather tubes.



5. Remove the two breather / air filter base mounting bolts shown.
NOTE: K&N Engineering, Inc. recommends that customers do not discard the factory air intake components.



6. Remove the air filter base from the vehicle as shown.



7. Install the supplied crankcase breather tube using the provided breather bolts and washers.
NOTE: Place one washer on each side of the of the breather tube.



8. Trim the provided crankcase breather hose to a length of 1.5" and then install it onto the K&N® intake tube as shown.



9. Install the K&N® intake tube onto the throttle body along with the provided gasket and secure with the provided mounting bolts.
NOTE: Apply a drop of the provided thread locker to the threads of the intake tube mounting bolts.



10. Install the provided K&N® air filter and secure with the provided hose clamp. A black hose clamp is being supplied with kit. This clamp is intended to clamp the filter to the intake tube.

NOTE: Drycharger® air filter wrap; Part # RC3680DK is available to purchase separately. To learn more about Drycharger® filter wraps or look up color availability please visit <http://www.knfilters.com>.

11. Reconnect the vehicle's negative battery cable. Double check to make sure everything is tight and properly positioned before starting the vehicle.

12. The C.A.R.B. exemption sticker, (attached), must be visible, so the emissions inspector can see it when the vehicle is required to be tested for emissions. California requires testing every two years, other states may vary.

13. It will be necessary for all K&N® high flow intake systems to be checked periodically for realignment, clearance and tightening of all connections. Failure to follow the above instructions or proper maintenance may void warranty.

ROAD TESTING:

1. Start the engine with the transmission in neutral or park. Listen for air leaks or odd noises. For air leaks secure hoses and connections. For odd noises, find cause and repair before proceeding. This kit will function identically to the factory system except for being louder and much more responsive.

2. Test drive the vehicle. Listen for odd noises or rattles and fix as necessary.

3. If road test is fine, you can now enjoy the added power and performance from your kit.

4. K&N Engineering, Inc., suggests checking the air filter element periodically for excessive dirt build-up. When the element becomes covered in dirt (or once a year), service it according to the instructions on the Recharger® service kit, part number 99-5050 or 99-5000.

INTAKE SYSTEMS FOR VEHICLES LISTED ARE 50 STATE LEGAL. SEE KNFILTERS.COM FOR CARB STATUS ON EACH PART FOR A SPECIFIC VEHICLE.