



PERFORMANCE EXHAUST SYSTEM



INSTALLATION INSTRUCTIONS

67-3109

CHEVROLET / GMC

2019-20 Silverado 1500

2019-20 Sierra 1500

V6-4.3L / V8-5.3L

TOOLS NEEDED:

Ratchet
13mm socket
15mm socket

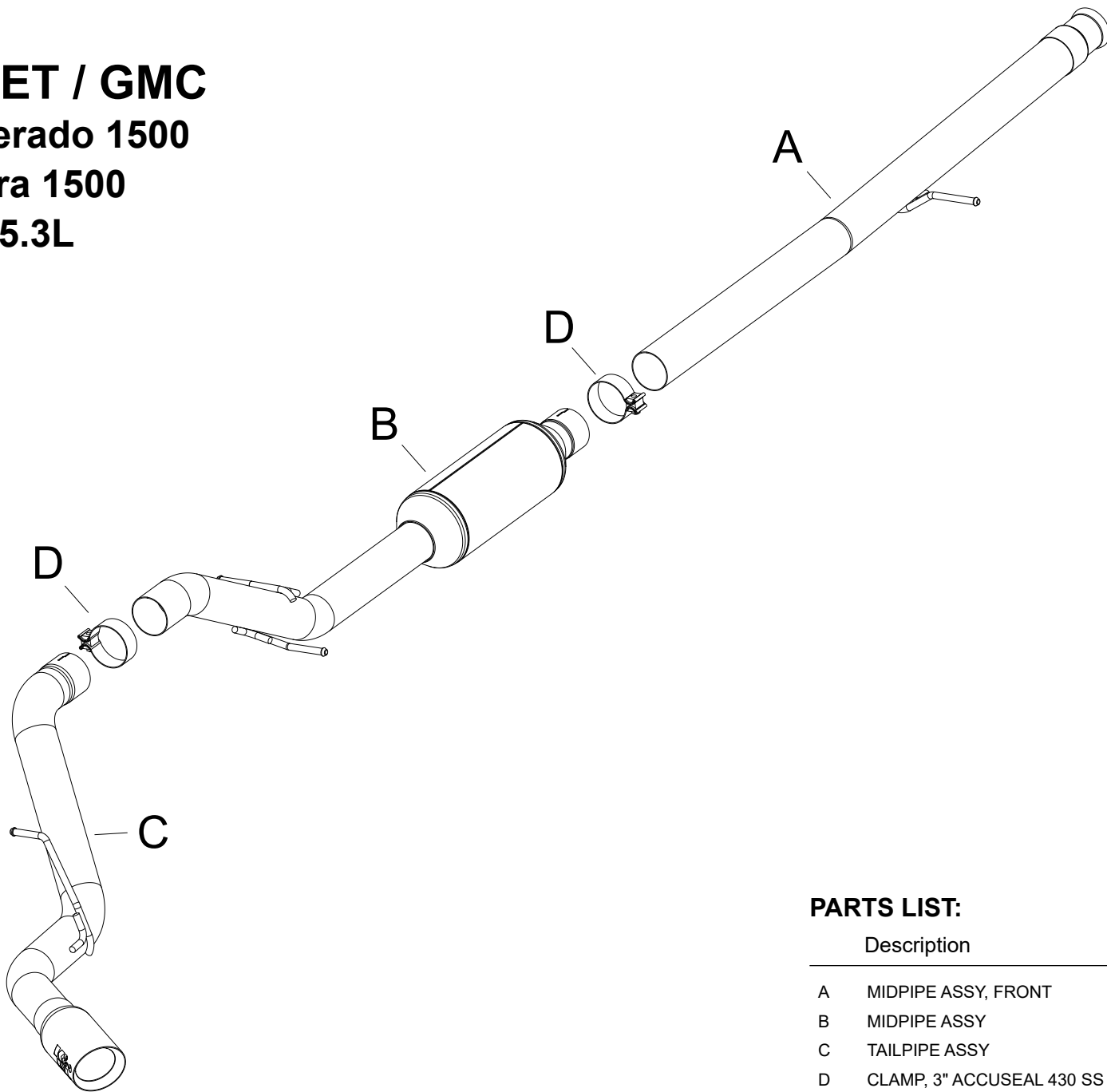

PARTS LIST:

	Description	Qty.	Part #
A	MIDPIPE ASSY, FRONT	1	344114
B	MIDPIPE ASSY	1	344115
C	TAILPIPE ASSY	1	344116
D	CLAMP, 3" ACCUSEAL 430 SS	2	RH-A30BF

TO START:

1. Turn off the ignition and allow engine and exhaust to cool to the touch.

WARNING: Exhaust components can be extremely hot after vehicle operation and can severely burn you.

Raise the vehicle to access the factory exhaust system with a lift or appropriate jack and properly positioned stands. It may be helpful to spray all existing hardware and hanger assemblies being removed with a penetrating oil or similar lubricant and allow to soak, especially if older and rusted.

WARNING: If working without a lift always use the correct jack points and lifting procedures specified by the vehicle manufacturer. Serious injury or death could occur if proper safety measures are not followed.



2. Unless a vehicle lift is available cutting the stock exhaust will be mandatory to remove. Cut rear tailpipe 2" from rear hanger just above the axle where shown.



3. Remove rear tail pipe section by sliding tail pipe off rear hanger (leave rubber hanger on vehicle).



4. Once rear tail pipe has been removed loosen front conical clamp connecting tail pipe to head pipe.

NOTE: do not damage or discard this clamp as it will be reused for the K&N Exhaust System.



5. Remove muffler assembly from remaining hangers.

6. Slide rearward to allow the exhaust to clear the front crossmember and drop out.

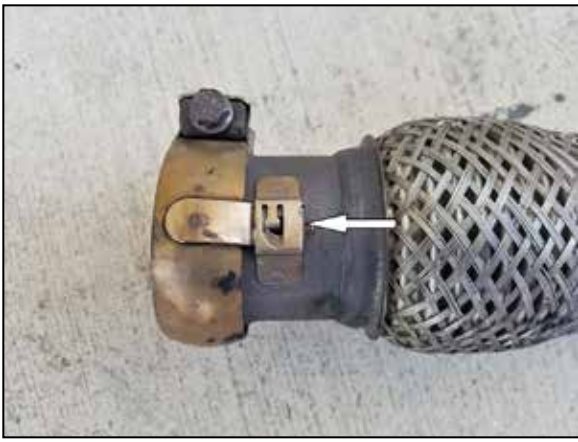

7. Once stock system is removed, remove the conical clamp by prying retaining tang upwards.



8. For vehicles with 147.5" wheelbase 9.5" must be cut off the end opposite to the conical end connecting to the head pipe (As shown). For vehicles with 157" wheelbase it does not need to be cut.

NOTE Once the length has been cut, it is recommended to clean and deburr the edge.

9. Install the stock conical clamp from the OEM system on the flared end of the mid pipe.

10. Assemble mid pipe and muffler by sliding on provided band clamp then inserting straight cut end into the front of the muffler.

NOTE: Do not tighten the muffler connection at this time.



11. Slide mid pipe and muffler assembly into position on the vehicle by first using the hangers on the muffler end. Once inserted, then slide assembly rearward allowing the mid pipe to move into position to seat against head pipe with the factory conical clamp.



12. Slide band clamp on to the front of the tail pipe section. Then slide tail pipe section into muffler section.

NOTE: Do not tighten the tail pipe connection at this time. Only enough to allow positioning of the tip to the body of the vehicle.

13. Check alignment and reposition as necessary. Once final position is satisfactory, tighten all hardware and band clamps from front to rear of vehicle. Clean exhaust tip of any finger prints or grease marks.

NOTE: All band clamps should be torqued to 40-45 ft-lbs



14. Double check to make sure everything is tight and properly positioned before lowering the vehicle to the ground.

ROAD TESTING:

1. Start the engine with the transmission in neutral or park, and the parking brake engaged. Listen for exhaust leaks or odd noises. For exhaust leaks secure flanges and/or connections. For odd noises, find cause and repair before proceeding. This kit will function identically to the factory system except for being louder.

2. Test drive the vehicle. Listen for odd noises or rattles and fix as necessary.

3. If road test is fine, you can now enjoy the added power and performance from your exhaust system.