

INSTALLATION INSTRUCTIONS

69-6036TC
MAZDA
2021-24 // 3
L4-2.5 TURBO

TOOLS NEEDED:

- Ratchet
- Extension
- 10mm Socket
- 3mm Allen Key
- Flat Blade Screw Driver
- Phillips Screw Driver
- Side Cutters

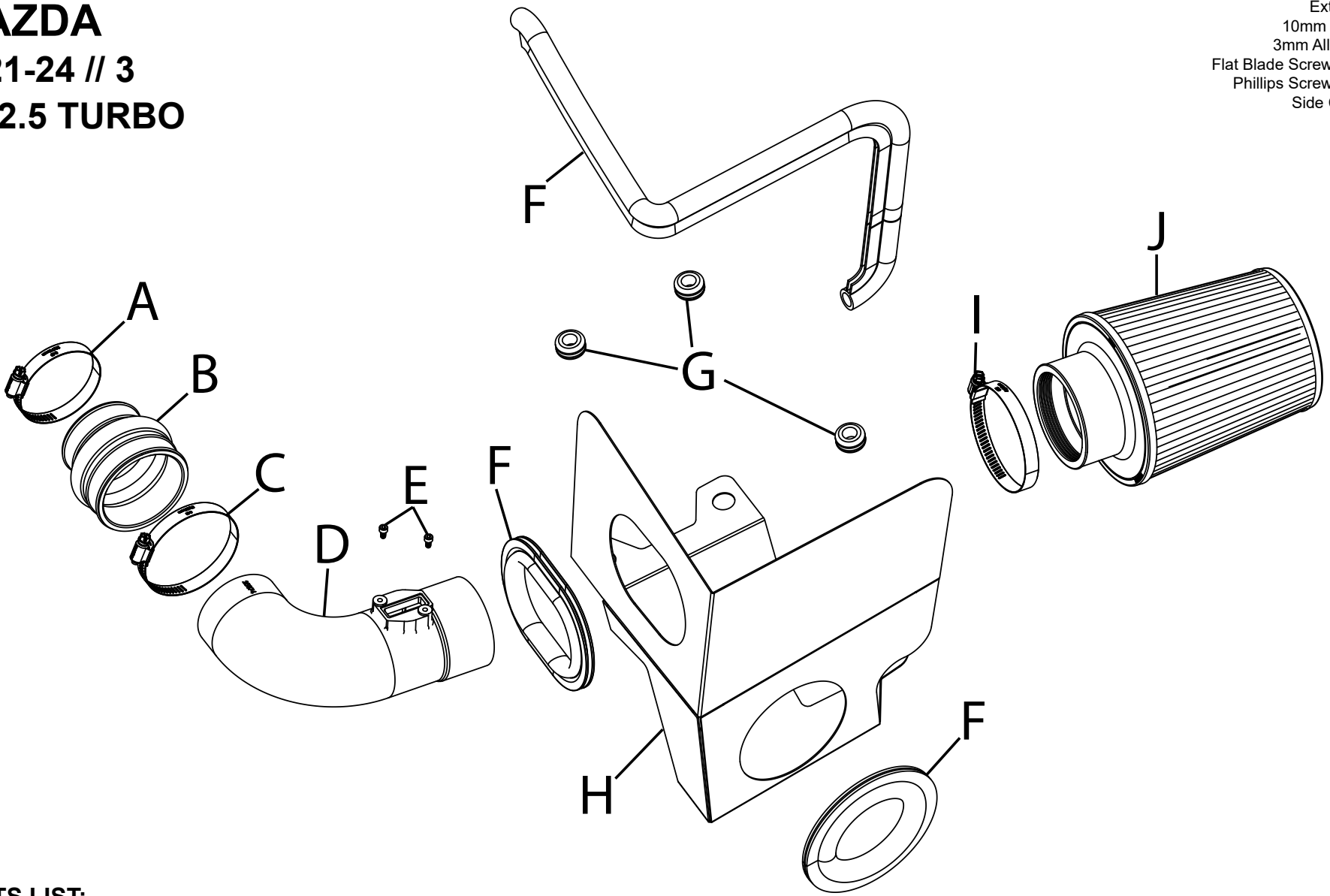

PARTS LIST:

Description	Qty.	Part #	Description	Qty.	Part #	Description	Qty.	Part #
A HOSE CLAMP; #44	1	08577	E BOLT; M4-.7 X 8MM, ALNHD	2	07733	I HOSE CLAMP; #52	1	08610
B HOSE; HUMP 2.5" / 3" X 3"	1	5-574	F EDGE TRIM; (66"L)	1	102472	J AIR FILTER	1	RU-5100
C HOSE CLAMP; #48	1	08601	G GROMMET; 1"OD , 1/2"ID	3	08064			
D TUBE; 3"OD X 11"L, (AL)	1	25874C	H HEAT SHIELD	1	073304			

If you need any assistance please call 1-800-858-3333 to speak with a representative in our Customer Service Center before returning the product.

NOTE: FAILURE TO FOLLOW INSTALLATION INSTRUCTIONS AND NOT USING THE PROVIDED HARDWARE MAY DAMAGE THE INTAKE TUBE, THROTTLE BODY AND ENGINE.

TO START:

1. Turn off the ignition and disconnect the negative battery cable.
NOTE: Disconnecting the negative battery cable erases pre-programmed electronic memories. Write down all memory settings before disconnecting the negative battery cable. Some radios will require an anti-theft code to be entered after the battery is reconnected. The anti-theft code is typically supplied with your owner's manual. In the event your vehicles anti-theft code cannot be recovered, contact an authorized dealership to obtain your vehicles anti-theft code.



2. Remove the two bolts that secure the fresh air intake duct to the core support.



3. Loosen the hose clamp that secures the factory intake hose to the turbo inlet. Disconnect the mass air sensor and unhook the wiring harness from the air filter housing. Release the mounting clips and then remove the air filter housing lid and intake hose from the vehicle.



4. Lift the lower air filter housing up off the mounting posts and then remove the lower air filter housing from the vehicle.

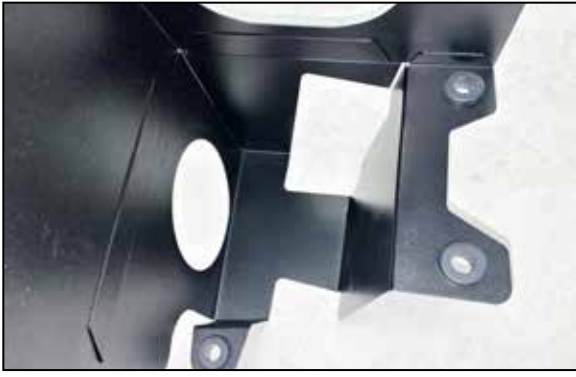

5. Install the provided grommets into the K&N heat shield as shown.

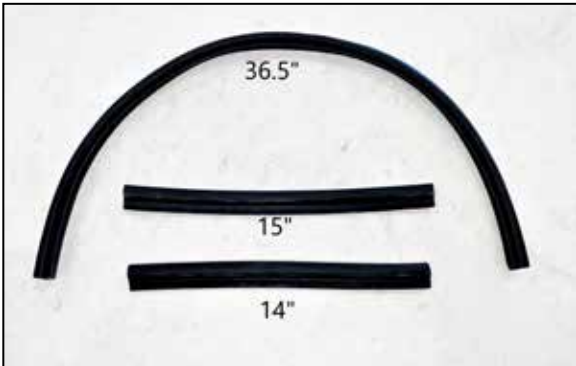

6. Cut the provided edge trim into sections as shown.



7. Install the edge trim from the previous step onto the heat shield as shown.



8. Release the tab that locks the fresh air duct onto the factory air filter housing, rotate the duct counterclockwise and then remove from the housing.



9. Install the fresh air intake duct into the K&N heat shield.



10. Install the heatshield assembly into the vehicle so the mounting posts insert into the grommets. Secure the fresh air duct with the factory hardware.



11. Install the provided hump coupler onto the turbo inlet and secure with the provided hose clamp.



12. Remove the mass air sensor from the factory air filter housing and then install it into the K&N intake tube. Secure the sensor with the provided hardware.



13. Install the intake tube assembly through the hole in the heat shield and then into the hump coupler and secure with the provided hose clamp.



14. Install the K&N filter onto the intake tube and secure with the provided hose clamp. Reconnect the mass air sensor electrical connection.



15. Apply the provided K&N decal onto the heat shield.



17. Reconnect the vehicle's negative battery cable. Double check to make sure everything is tight and properly positioned before starting the vehicle.

18. It will be necessary for all K&N® high flow intake systems to be checked periodically for realignment, clearance and tightening of all connections. Failure to follow the above instructions or proper maintenance may void warranty.

ROAD TESTING:

1. Start the engine with the transmission in neutral or park, and the parking brake engaged. Listen for air leaks or odd noises. For air leaks secure hoses and connections. For odd noises, find cause and repair before proceeding. This kit will function identically to the factory system except for being louder and much more responsive.

2. Test drive the vehicle. Listen for odd noises or rattles and fix as necessary.

3. If road test is fine, you can now enjoy the added power and performance from your kit.

4. K&N Engineering, Inc., requires cleaning the intake system's air filter element every 100,000 miles. When used in dusty or off-road environments, our filters will require cleaning more often. We recommend that you visually inspect your filter once every 25,000 miles to determine if the screen is still visible. When the screen is no longer visible some place on the filter element, it is time to clean it. To clean and re-oil, purchase our filter Recharger® service kit, part number 99-5050 or 99-5000 and follow the easy instructions.

NOT LEGAL FOR SALE OR USE ON ANY POLLUTION CONTROLLED MOTOR VEHICLE IN CALIFORNIA OR STATES ADOPTING CALIFORNIA EMISSION PROCEDURES.

See knfilters.com for CARB status on each part for a specific vehicle