



TYPHOON INTAKE SYSTEMS

INTAKE SYSTEMS FOR VEHICLES LISTED ARE 50 STATE LEGAL. SEE KNFILTERS.COM FOR CARB STATUS ON EACH PART FOR A SPECIFIC VEHICLE.

INSTALLATION INSTRUCTIONS

69-8704TP
LEXUS
2013-21 IS350
2013-20 GS350
2015-21 RC350
V6-3.5L
2014-15 IS250
V6-2.5L

TOOLS NEEDED:

- phillips screw driver
- flat blade screw driver

PARTS LIST:

Description	Qty.	Part #
A HOSE CLAMP #48	2	08601
B HOSE; 3.125" TO 3" ID X 2"L	2	084031
C HOSE CLAMP #44 STAINLESS	2	08560
D INTAKE TUBE	1	27617TP
E VENT; STRT, 5/8 BARBED 1/4	1	82638
F AIR FILTER	1	33-2452

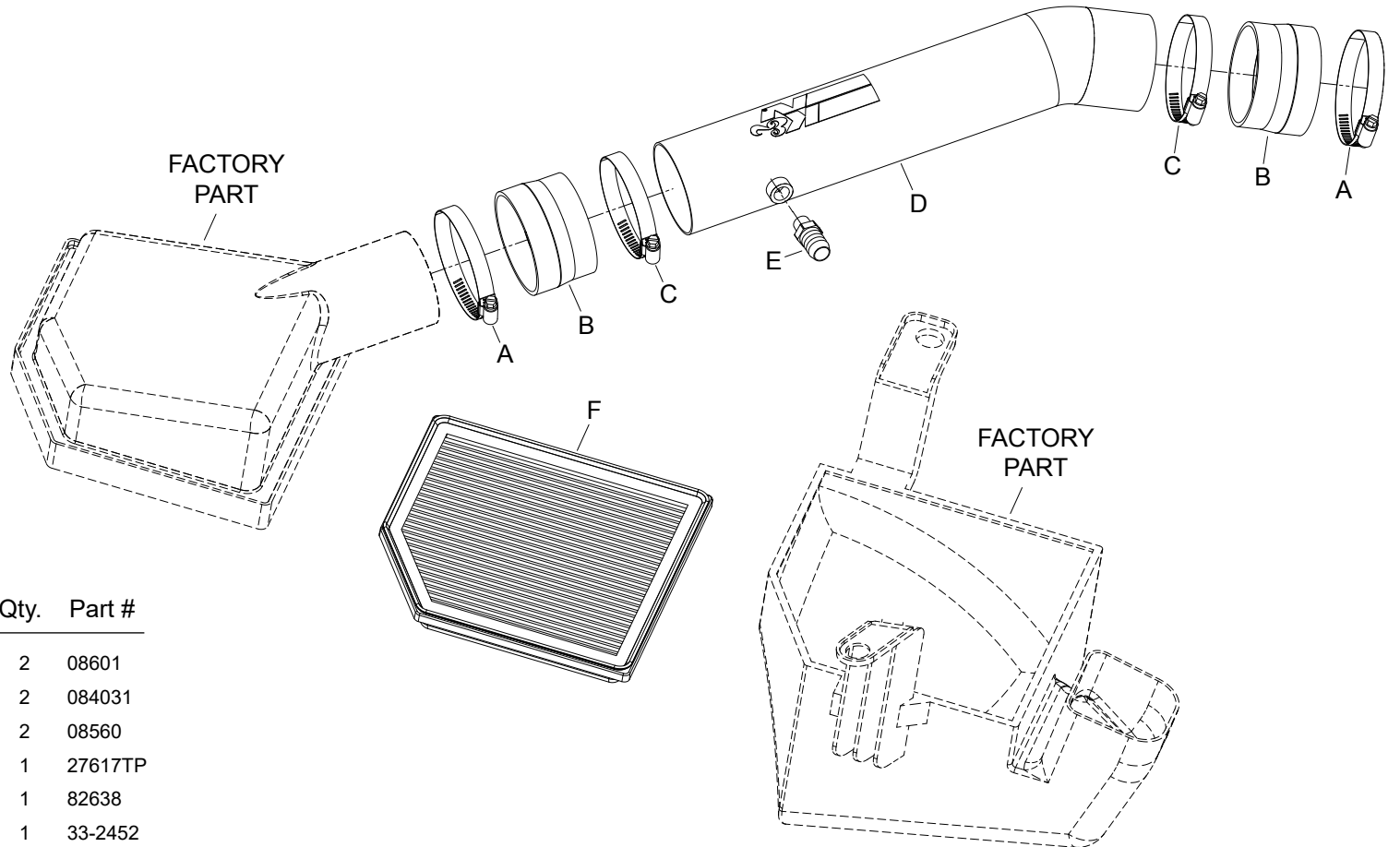

If you need any assistance please call 1-800-858-3333 to speak with a representative in our Customer Service Center before returning the product.

NOTE: FAILURE TO FOLLOW INSTALLATION INSTRUCTIONS AND NOT USING THE PROVIDED HARDWARE MAY DAMAGE THE INTAKE TUBE, THROTTLE BODY AND ENGINE.

TO START:

1. Turn off the ignition and disconnect the negative battery cable.
NOTE: Disconnecting the negative battery cable erases pre-programmed electronic memories. Write down all memory settings before disconnecting the negative battery cable. Some radios will require an anti-theft code to be entered after the battery is reconnected. The anti-theft code is typically supplied with your owner's manual. In the event your vehicles anti-theft code cannot be recovered, contact an authorized dealership to obtain your vehicles anti-theft code.



2. Lift off the engine cover.



3. Release the spring clip securing the crank case breather hose to the factory intake tube and disconnect the crank case breather from the factory intake tube.



4. Loosen the two hose clamps securing the factory intake tube and then remove the factory intake hose from the vehicle.

NOTE: K&N Engineering, Inc., recommends that customers do not discard factory air intake.



5. Remove the four clips securing the cover panel to the core support and inner fender, and then remove the panel from the vehicle.

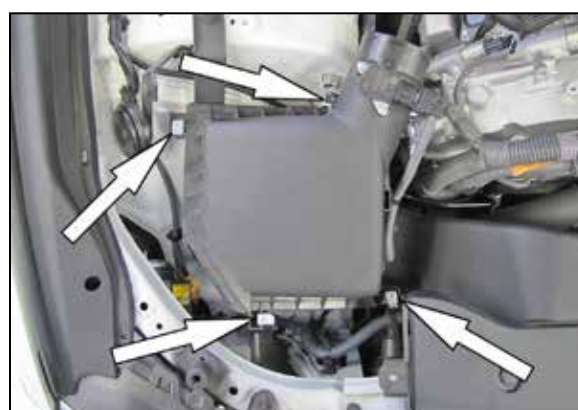

6. Release the four upper air box retaining clips and then remove the factory air filter.



7. Install the provided K&N® air filter; do not secure the upper air box lid at this time.



8. Install the provided vent fitting into the K&N® intake tube as shown.

NOTE: NPT fitting has tapered threads and only designed to be installed until hand tight, then tighten one rotation or when the fitting becomes difficult to return.



9. Install the provided coupling hoses (084031) onto the throttle body and air box as shown securing with the provided hose clamps



10. Install the K&N® intake tube into the hose at the throttle body and then into the hose at the upper air box. Secure the upper air box lid and then adjust the tube for best fit, secure the tube with the provided hose clamps.



11. Install the crank case vent hose onto the fitting installed into the K&N® intake tube.



12. Reinstall the cover over the air box and secure with the four factory retaining clips.



13. Reinstall the engine cover.



14. Reconnect the vehicle's negative battery cable. Double check to make sure everything is tight and properly positioned before starting the vehicle.

15. The C.A.R.B. exemption sticker, (attached), must be visible under the hood so that an emissions inspector can see it when the vehicle is required to be tested for emissions. California requires testing every two years, other states may vary.

16. It will be necessary for all K&N® high flow intake systems to be checked periodically for realignment, clearance and tightening of all connections. Failure to follow the above instructions or proper maintenance may void warranty.

ROAD TESTING:

1. Start the engine with the transmission in neutral or park, and the parking brake engaged. Listen for air leaks or odd noises. For air leaks secure hoses and connections. For odd noises, find cause and repair before proceeding. This kit will function identically to the factory system except for being louder and much more responsive.

2. Test drive the vehicle. Listen for odd noises or rattles and fix as necessary.

3. If road test is fine, you can now enjoy the added power and performance from your kit.

4. K&N Engineering, Inc., requires cleaning the intake system's air filter element every 100,000 miles. When used in dusty or off-road environments, our filters will require cleaning more often. We recommend that you visually inspect your filter once every 25,000 miles to determine if the screen is still visible. When the screen is no longer visible some place on the filter element, it is time to clean it. To clean and re-oil, purchase our filter Recharger® service kit, part number 99-5050 or 99-5000 and follow the easy instructions.

INTAKE SYSTEMS FOR VEHICLES LISTED ARE 50 STATE LEGAL. SEE KNFILTERS.COM FOR CARB STATUS ON EACH PART FOR A SPECIFIC VEHICLE.