



NOT LEGAL FOR SALE OR USE ON ANY POLLUTION CONTROLLED MOTOR VEHICLE IN CALIFORNIA OR STATES ADOPTING CALIFORNIA EMISSION PROCEDURES.
See knfilters.com for CARB status on each part for a specific vehicle

INSTALLATION INSTRUCTIONS

77-1001KC

FORD

2015-23 F-150

2017-23 F-150 Raptor

2015-23 Expedition

V6-3.5L

NOTE: Does not fit "Powerboost" models.

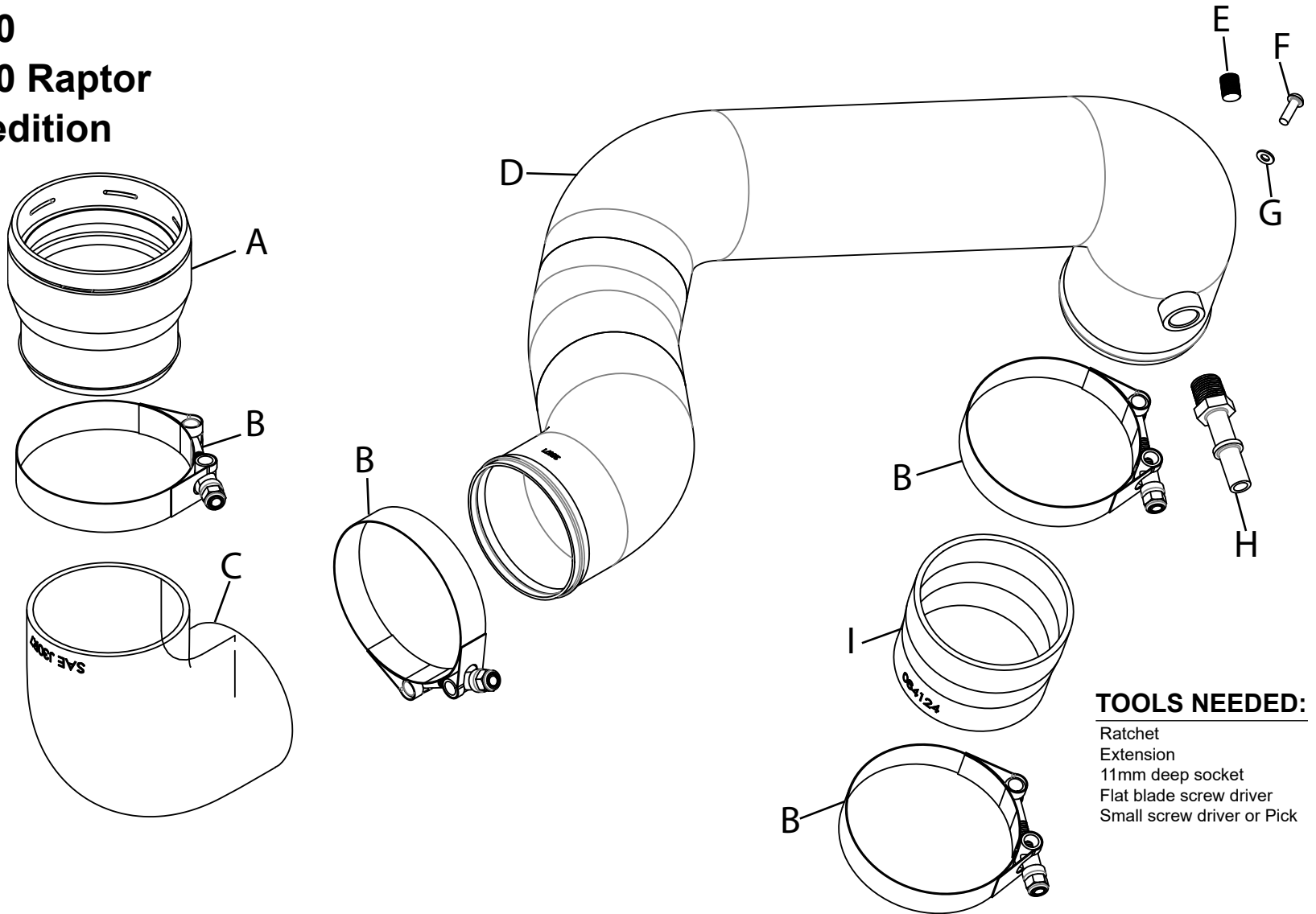

TOOLS NEEDED:

- Ratchet
- Extension
- 11mm deep socket
- Flat blade screw driver
- Small screw driver or Pick

PARTS LIST:

Description	Qty.	Part #	Description	Qty.	Part #	Description	Qty.	Part #
A COUPLER; QC. 3.25"OD, (AL) CLAMP ON	1	088102	D TUBE; 3.25"ID X 8"L, (AL)	1	25871C	G WASHER; 5MM FLAT	1	08212
B HOSE CLAMP; T-BOLT, #362	4	21855	E PLUG; STAINLESS STEEL 1/8"NPT	1	1-1014	H FITTING; 3/8NPT TO .460"OD X 1.88"L Q.C.	1	82640
C HOSE; 3.25"ID X 8"L, 90DEG ANGLED	1	084123	F BOLT; M5 X .8 X 20MM, BTNHD	1	22208	I HOSE; 3.25"ID TO 3.125" X 3.0"L	1	084124

If you need any assistance please call 1-800-858-3333 to speak with a representative in our Customer Service Center before returning the product.

NOTE: FAILURE TO FOLLOW INSTALLATION INSTRUCTIONS AND NOT USING THE PROVIDED HARDWARE MAY DAMAGE THE INTAKE TUBE, THROTTLE BODY AND ENGINE.

TO START:

1. Turn off the ignition and disconnect the negative battery cable.

NOTE: Disconnecting the negative battery cable erases pre-programmed electronic memories. Write down all memory settings before disconnecting the negative battery cable. Some radios will require an anti-theft code to be entered after the battery is reconnected. The anti-theft code is typically supplied with your owner's manual. In the event your vehicles anti-theft code cannot be recovered, contact an authorized dealership to obtain your vehicles anti-theft code.



2. Loosen the three hose clamps that secure the factory intake tube to the turbo inlet tubes and air filter housing and then remove the intake tube from the vehicle.



3. Loosen the hose clamp that secures the factory charge tube to the throttle body.

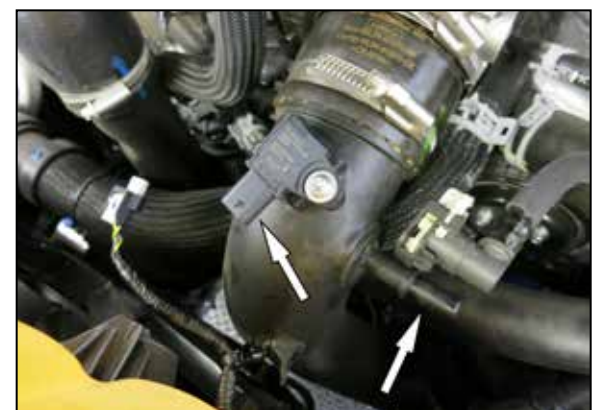

4. Disconnect the pressure sensor electrical connection. Disconnect the vent line quick disconnect fitting.



5. Disconnect the charge tube from the throttle body.



6. Remove the two bolts that secure the coolant reservoir, this will allow the reservoir to be moved to allow easier access while working on the lower section of the charge tube.



7. Rotate the BOV locking ring counterclockwise to unlock and then separate the BOV hose from the fitting.



8. Using a small screwdriver or similar tool, release the locking clip that secures the factory charge tube to the intercooler and then disconnect the tube from the intercooler connection.



9. Remove the factory charge tube from the vehicle.



10. Remove the O-ring and retaining clip from the factory charge tube.



11. Install the short side of the provided 90-degree hose onto the provided quick connect coupler along with the hose clamps. Tighten the clamp to secure the hose to the fitting.

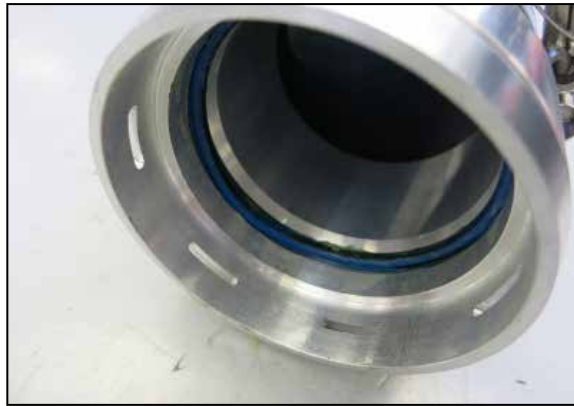

12. Install the factory O-ring into the K&N quick connect fitting.

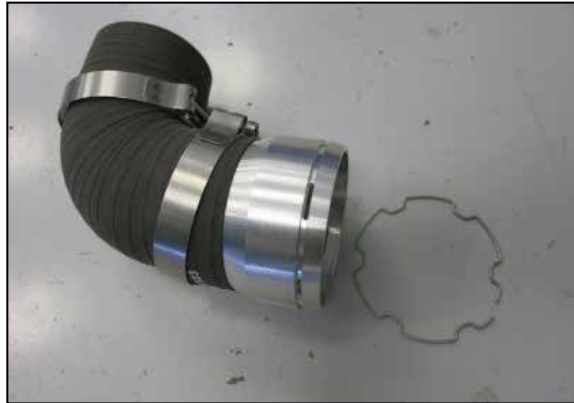

13. Install the factory locking clip onto the K&N quick connect fitting.



14. Remove the Pressure sensor from the factory charge tube and then install it into the K&N charge tube using the provided hardware. Install the quick connect npt fitting into the K&N charge tube and then install the 1/8npt plug. Be sure to apply thread sealant to the threads of the 1/8npt plug before installing.



15. Install the provided step hose onto the throttle body and secure with the provided clamp.



16. Install the quick connector/90deg. hose assembly onto the intercooler, push the connector firmly onto the intercooler until you hear an audible click indicating the locking ring has snapped into position.



17. Feed the K&N charge tube into position from the top of the engine compartment. Adjust the 90deg hose so that the charge tube inserts into the hose.



18. Position the tube into the hose at the throttle body, adjust the entire assembly for best fit and then secure the hose clamps. Reconnect the BOV hose onto position and lock by turning the locking ring clockwise.



19. Install the K&N decal onto the charge tube.



20. Connect the factory vent line to the quick connect fitting installed into the K&N charge tube.



21. Reconnect the pressure sensor electrical connection.



22. Reinstall the intake tube and secure with the factory clamps.

23. Reconnect the vehicle's negative battery cable. Double check to make sure everything is tight and properly positioned before starting the vehicle.

24. It will be necessary for all K&N® high flow intake systems to be checked periodically for realignment, clearance and tightening of all connections. Failure to follow the above instructions or proper maintenance may void warranty.

ROAD TESTING:

1. Start the engine with the transmission in neutral or park, and the parking brake engaged. Listen for air leaks or odd noises. For air leaks secure hoses and connections. For odd noises, find cause and repair before proceeding. This kit will function identically to the factory system except for being louder and much more responsive.

2. Test drive the vehicle. Listen for odd noises or rattles and fix as necessary.

3. If road test is fine, you can now enjoy the added power and performance from your kit.

4. K&N Engineering, Inc., requires cleaning the intake system's air filter element every 100,000 miles. When used in dusty or off-road environments, our filters will require cleaning more often. We recommend that you visually inspect your filter once every 25,000 miles to determine if the screen is still visible. When the screen is no longer visible some place on the filter element, it is time to clean it. To clean and re-oil, purchase our filter Recharger® service kit, part number 99-5050 or 99-5000 and follow the easy instructions.

NOT LEGAL FOR SALE OR USE ON ANY POLLUTION CONTROLLED MOTOR VEHICLE IN CALIFORNIA OR STATES ADOPTING CALIFORNIA EMISSION PROCEDURES.

See knfilters.com for CARB status on each part for a specific vehicle