



NOT LEGAL FOR SALE OR USE ON ANY POLLUTION CONTROLLED MOTOR VEHICLE IN CALIFORNIA OR STATES ADOPTING CALIFORNIA EMISSION PROCEDURES.

See knfilters.com for CARB status on each part for a specific vehicle

## INSTALLATION INSTRUCTIONS

**77-1583KP**  
**DODGE**  
**2019-22 / RAM 2500-3500**  
**6.4L V8**

### TOOLS NEEDED:

Flat Blade Screw driver  
 4mm allen key  
 3/4" wrench

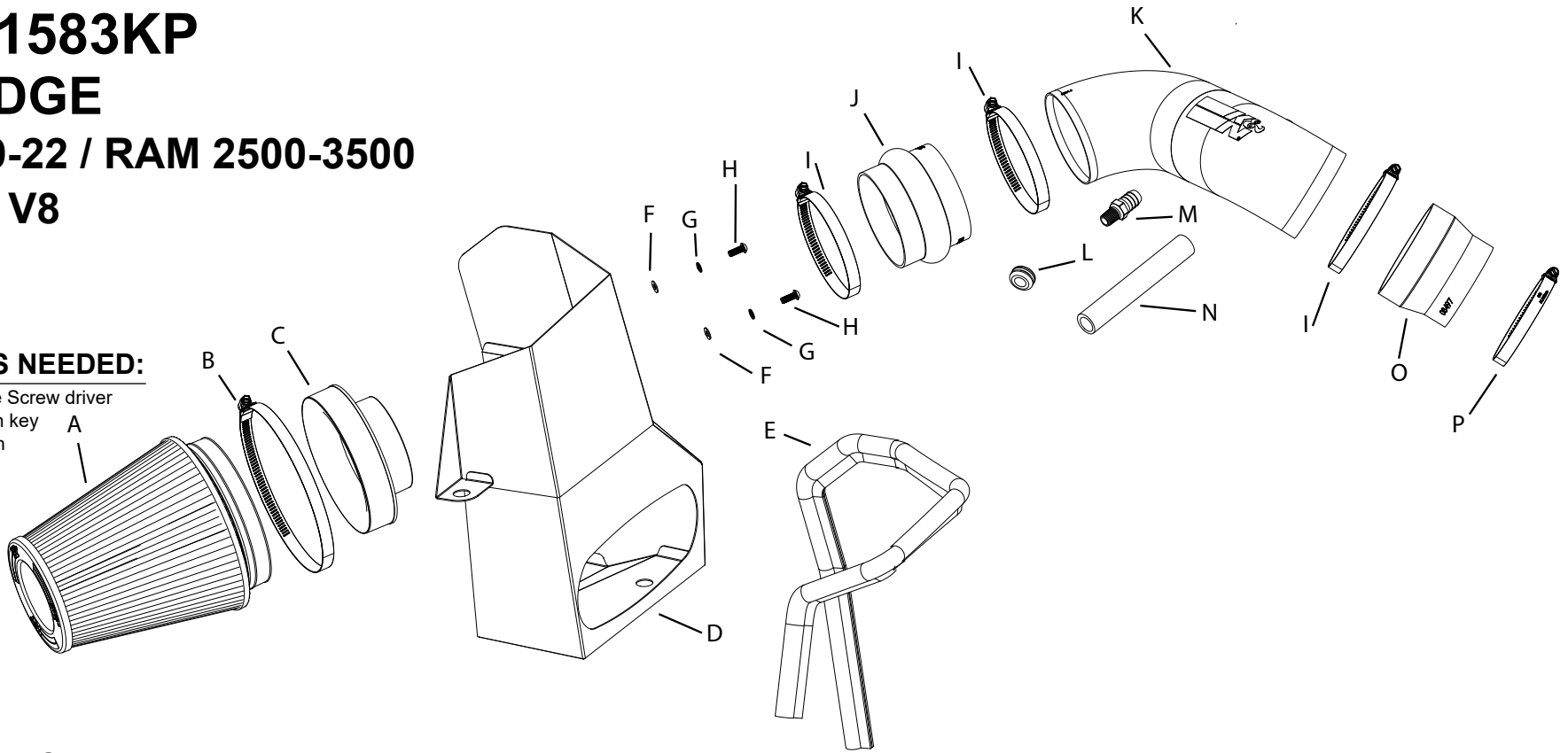

### PARTS LIST:

Description	Qty.	Part #	Description	Qty.	Part #	Description	Qty.	Part #
A AIR FILTER	1	RU-1020	G WASHER; M6 SPLIT LOCK	2	1-3025	M FITTING; VENT, 1/4"NPT	1	82638
B HOSE CLAMP; #104	1	08697	H BOLT; M6 X 1 X 16MM	2	07730	N HOSE; 3/4"ID X 6"L	1	5-4006
C ADAPTER; #454	1	27300	I HOSE CLAMP; #64 STAINLESS	3	08645	O HOSE; 4"ID TO 3.5"ID X 3"L	1	08497
D HEAT SHIELD	1	073302	J HOSE; HUMP 4"ID X 3"L	1	08418	P HOSE CLAMP; #56	1	08620
E EDGE TRIM; 39"L	1	102496A	K TUBE; (BRIGHT)	1	25816P			
F WASHER; 6MM FLAT	2	08269	L GROMMET; 1"OD	1	08064			

**If you need any assistance please call 1-800-858-3333 to speak with a representative in our Customer Service Center before returning the product.**

**NOTE: FAILURE TO FOLLOW INSTALLATION INSTRUCTIONS AND NOT USING THE PROVIDED HARDWARE MAY DAMAGE THE INTAKE TUBE, THROTTLE BODY AND ENGINE.**

### TO START:

1. Turn off the ignition and disconnect the negative battery cable.

**NOTE: Disconnecting the negative battery cable erases pre-programmed electronic memories. Write down all memory settings before disconnecting the negative battery cable. Some radios will require an anti-theft code to be entered after the battery is reconnected. The anti-theft code is typically supplied with your owner's manual. In the event your vehicles anti-theft code cannot be recovered, contact an authorized dealership to obtain your vehicles anti-theft code.**



2. Lift off the decorative engine cover and set aside.



3. Disconnect the IAT sensor electrical connection and unhook the wiring harness from intake tube. Then disconnect the CCV hose from the intake tube.



4. Loosen the hose clamps that secure the factory intake tube and then remove the intake tube from the vehicle.



5. Disconnect the fresh air intake duct from the factory air filter housing



6. Pull the factory air filter housing straight up and remove it from the vehicle. **NOTE: K&N Engineering, Inc., recommends that customers do not discard factory air intake.**



7. Install the provided edge trim onto the K&N heat shield as shown.



8. Install the filter adapter into the heat shield and secure with the provided hardware.



9. Remove the three mounting grommets from the factory air filter housing and install them into the K&N heat shield as shown.



10. Install the K&N heat shield into the vehicle.



11. Insert the fresh air intake duct into the K&N heat shield.



12. Install the provided hump coupler onto the filter adapter and secure with the provided hose clamp.



13. Install the step coupler onto the throttle body and secure with the provided hardware.



14. Install the provided vent fitting into the K&N intake tube as shown. **NOTE: NPT fitting has tapered threads and only designed to be installed until hand tight, then tighten one rotation or when the fitting becomes difficult to return.**



15. Remove the IAT sensor from the factory intake tube and then remove the O-Ring from the sensor. Using the provided grommet, install the sensor into the K&N intake tube as shown. **NOTE: The IAT sensor is very fragile, use caution while handling the sensor so as not to damage it.**



16. Install the intake tube into the couplers, position for best fit and then secure with the provided hose clamps.



17. Remove the short section of the factory CCV hose and install the straight section provided. Connect the CCV hose to the fitting installed into the K&N intake tube.



18. Reconnect the IAT sensor electrical connection.



19. Reinstall the engine cover.



20. Install the K&N air filter and secure with the provided hose clamp.



21. Reconnect the vehicle's negative battery cable. Double check to make sure everything is tight and properly positioned before starting the vehicle.

22. It will be necessary for all K&N® high flow intake systems to be checked periodically for realignment, clearance and tightening of all connections. Failure to follow the above instructions or proper maintenance may void warranty.

#### ROAD TESTING:

1. Start the engine with the transmission in neutral or park, and the parking brake engaged. Listen for air leaks or odd noises. For air leaks secure hoses and connections. For odd noises, find cause and repair before proceeding. This kit will function identically to the factory system except for being louder and much more responsive.

2. Test drive the vehicle. Listen for odd noises or rattles and fix as necessary.

3. If road test is fine, you can now enjoy the added power and performance from your kit.

4. K&N Engineering, Inc., requires cleaning the intake system's air filter element every 100,000 miles. When used in dusty or off-road environments, our filters will require cleaning more often. We recommend that you visually inspect your filter once every 25,000 miles to determine if the screen is still visible. When the screen is no longer visible some place on the filter element, it is time to clean it. To clean and re-oil, purchase our filter Recharger® service kit, part number 99-5050 or 99-5000 and follow the easy instructions.

**NOT LEGAL FOR SALE OR USE ON ANY POLLUTION CONTROLLED MOTOR VEHICLE IN CALIFORNIA OR STATES ADOPTING CALIFORNIA EMISSION PROCEDURES.**

See [knfilters.com](http://knfilters.com) for CARB status on each part for a specific vehicle