



INTAKE SYSTEMS FOR VEHICLES LISTED ARE 50 STATE LEGAL. SEE KNFILTERS.COM FOR CARB STATUS ON EACH PART FOR A SPECIFIC VEHICLE.

## INSTALLATION INSTRUCTIONS

### 77-3082KP CHEVROLET / GMC / CADILLAC 2014-15 Silverado 1500 / Sierra 1500 2015 Tahoe / Suburban / Yukon / Escalade ESV V8-5.3L / 6.2L

NOTE: This kit was not designed to fit vehicles with a body lift.

#### TOOLS NEEDED:

ratchet  
extension  
10mm socket  
flat blade screw driver  
T10 TORX  
4mm allen key  
3mm allen key  
3/4" wrench

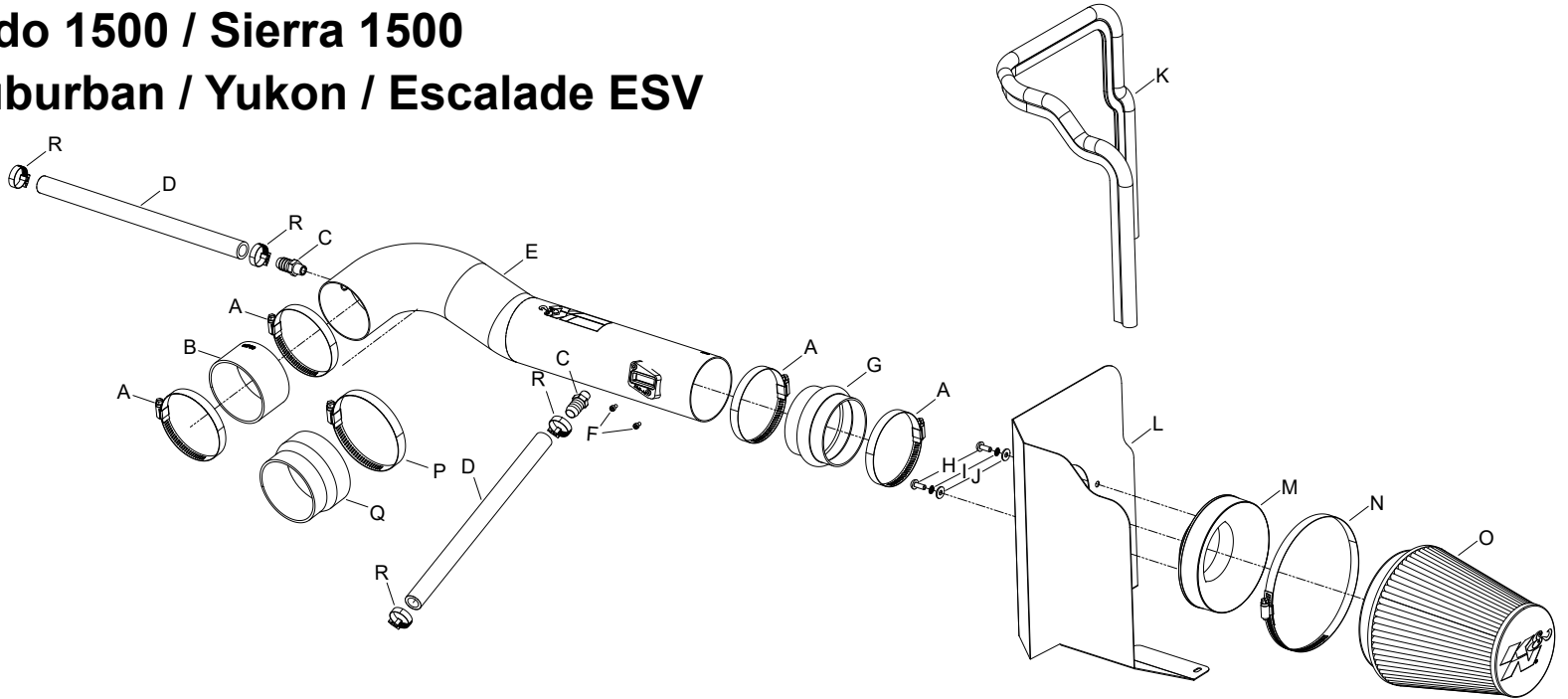

#### PARTS LIST:

Description	Qty.	Part #	Description	Qty.	Part #	Description	Qty.	Part #
A HOSE CLAMP #56	4	08620	G HOSE; HUMP 3.5"ID X 2.5"L	1	08699	M ADAPTER; UNIVERSAL, 6"	1	21512-1
B HOSE; 3.5" ID X 2"L	1	08698	H BOLT; M6 X 1 X 16MM	2	07730	N HOSE CLAMP #104	1	08697
C VENT; STRT, 5/8 BARBED NPT	2	08911-2	I WASHER; M6 SPLIT LOCK ZINC	2	1-3025	O AIR FILTER	1	RU-1041
D HOSE; 5/8"ID X 14"L	2	084083	J WASHER; 6MM, FLAT	2	08269	P HOSE CLAMP #64	1	08645
E INTAKE TUBE; (AL)	1	27610KP	K EDGE TRIM; 44"L	1	102486A	Q HOSE; 4"ID to 3.5"ID x 3"L	1	08497
F BOLT; M4-.7 x 8 MM	2	07733	L HEAT SHIELD	1	073155-1A	R HOSE CLAMP; #10 MINI	4	08411

If you need any assistance please call 1-800-858-3333 to speak with a representative in our Customer Service Center before returning the product.

**NOTE: FAILURE TO FOLLOW INSTALLATION INSTRUCTIONS AND NOT USING THE PROVIDED HARDWARE MAY DAMAGE THE INTAKE TUBE, THROTTLE BODY AND ENGINE.**

#### TO START:

1. Turn off the ignition and disconnect the negative battery cable.

NOTE: Disconnecting the negative battery cable erases pre-programmed electronic memories. Write down all memory settings before disconnecting the negative battery cable. Some radios will require an anti-theft code to be entered after the battery is reconnected. The anti-theft code is typically supplied with your owner's manual. In the event your vehicles anti-theft code cannot be recovered, contact an authorized dealership to obtain your vehicles anti-theft code.



2. Disconnect the mass air sensor electrical connection.

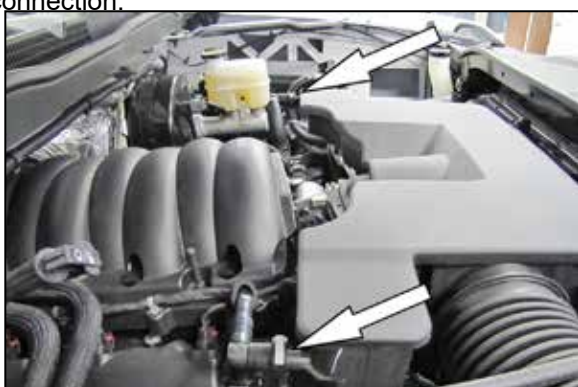

3. Disconnect the two crank case vent tubes from the intake plenum.



4. Loosen the two hose clamps securing the intake plenum to the factory air box and to the throttle body.



5. Remove the intake plenum from the vehicle.



6. Pull up the air box to release it from the mounting grommets and then remove the factory air box from the vehicle.

NOTE: It will be necessary to unhook the mass air sensor wiring harness from the air box as it is removed.

NOTE: K&N Engineering, Inc., recommends that customers do not discard factory air intake.

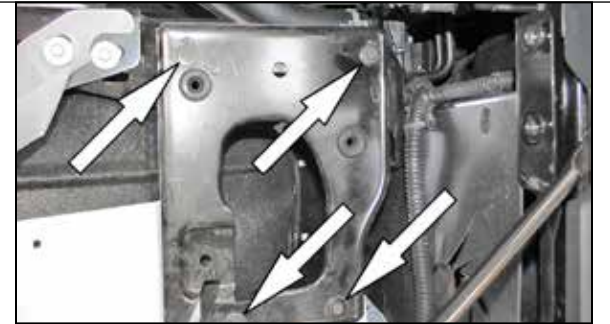

7. Remove the four bolts securing the air box mounting tray and then remove the tray from the vehicle. NOTE: Three of the bolts will be reused in a latter step.



8. Install the provided edge trim onto the heat shield as shown. NOTE: Some trimming of the edge trim will be necessary.



9. Install the heat shield assembly and secure to the air box mounting plate location using the three factory bolts from step #7.



10. Install the filter adapter into the K&N® air filter and secure with the provided hose clamp.



11. Install the filter assembly into the heat shield filter top first, then rotate the filter and pass the adapter through the hole in the heat shield. Secure the filter adapter to the heat shield using the provided hardware.



12. Remove the two factory crank case vent tubes from the vehicle.



13. Install the coupling hose (08698 for 5.3L, 08497 for 6.2L) onto the throttle body and secure with the provided hose clamp.



14. Install the coupling hose (08699) to the filter adapter and secure with the provided hose clamp.



15. Remove the mass air sensor from the factory air box.



16. Install the mass air sensor into the K&N intake tube and secure with the provided hardware. Install the provided CCV fitting into the K&N intake tube as shown. **NOTE: NPT fittings have tapered threads, hand tighten then rotate 1 revolution with a wrench until tight and difficult to turn. Over tightening will damage the fitting and tube.**



17. Install the remaining CCV fitting into the K&N intake tube as shown. **NOTE: NPT fittings have tapered threads, hand tighten then rotate 1 revolution with a wrench until tight and difficult to turn. Over tightening will damage the fitting and tube.**



18. Install the K&N® intake tube into the hose at the filter adapter and then into the hose at the throttle body, adjust the tube for best fit and then secure with the provided hose clamps.



19. Install the provided CCV hoses onto the valve cover ports and connect the driver side hose to the K&N intake tube and secure with the provided hose clamps.



20. Connect the passenger side CCV hose to the K&N intake tube and secure with the provided hose clamps. Reconnect the mass air sensor electrical connection.



21. Reconnect the vehicle's negative battery cable. Double check to make sure everything is tight and properly positioned before starting the vehicle.

22. The C.A.R.B. exemption sticker, (attached), must be visible under the hood so that an emissions inspector can see it when the vehicle is required to be tested for emissions. California requires testing every two years, other states may vary.

23. **NOTE:** Most General Motors vehicles have the Vehicle Emissions Certification Information (VECI) label affixed to the air filter box. In order to be compliant with California emissions laws, the label **MUST** remain in the engine compartment. If the Vehicle Emission Control Information label is removed during modification, a new replacement label must be obtained and installed in a readily visible position in the engine compartment. The label shall not be affixed to any equipment which is easily detached from the vehicle. We recommend that the label is affixed to the underside of the hood adjacent to the hood latch. The label is Vehicle Identification Number dependent and can be ordered from the vehicle dealership. In order to receive the proper decal please bring your VIN with you. Failure to have the VECI under the hood may result in failure of a pre-registration smog test.

24. **K&N AIR FILTER MONITOR LIGHT NOTE:** Some vehicle may be equipped with a "Air Filter Monitor" system that will send a message to the instrument cluster indicating that the air filter needs to be replaced. This system is calibrated for the OEM intake system and air filter and will not be accurate when K&N® products are in use. Always refer to [WWW.KNFILTERS.COM](http://WWW.KNFILTERS.COM) for K&N® air filter service procedures. If the "Air Filter Monitor" system indicates to replace the air filter, reset the system per the vehicle owner's manual.

25. It will be necessary for all K&N® high flow intake systems to be checked periodically for realignment, clearance and tightening of all connections. Failure to follow the above instructions or proper maintenance may void warranty.

#### ROAD TESTING:

1. Start the engine with the transmission in neutral or park, and the parking brake engaged. Listen for air leaks or odd noises. For air leaks secure hoses and connections. For odd noises, find cause and repair before proceeding. This kit will function identically to the factory system except for being louder and much more responsive.

2. Test drive the vehicle. Listen for odd noises or rattles and fix as necessary.

3. If road test is fine, you can now enjoy the added power and performance from your kit.

4. K&N Engineering, Inc., requires cleaning the intake system's air filter element every 100,000 miles. When used in dusty or off-road environments, our filters will require cleaning more often. We recommend that you visually inspect your filter once every 25,000 miles to determine if the screen is still visible. When the screen is no longer visible some place on the filter element, it is time to clean it. To clean and re-oil, purchase our filter Recharger® service kit, part number 99-5050 or 99-5000 and follow the easy instructions.

**INTAKE SYSTEMS FOR VEHICLES LISTED ARE 50 STATE LEGAL. SEE KNFILTERS.COM FOR CARB STATUS ON EACH PART FOR A SPECIFIC VEHICLE.**