



INSTALLATION INSTRUCTIONS

Not legal for sale or use in California on any pollution controlled motor vehicle.

77-3103KC CHEVROLET / GMC 2020-25 Silverado 2500-3500HD 2020-25 Sierra 2500-3500HD 6.6L

TOOLS NEEDED:

- Phillips Screw Driver
- Flat Blade Screw Driver
- T20 Torx
- 3mm Allen
- 4mm Allen
- 10mm Wrench

NOTE: This kit was not designed to fit vehicles with a body lift.

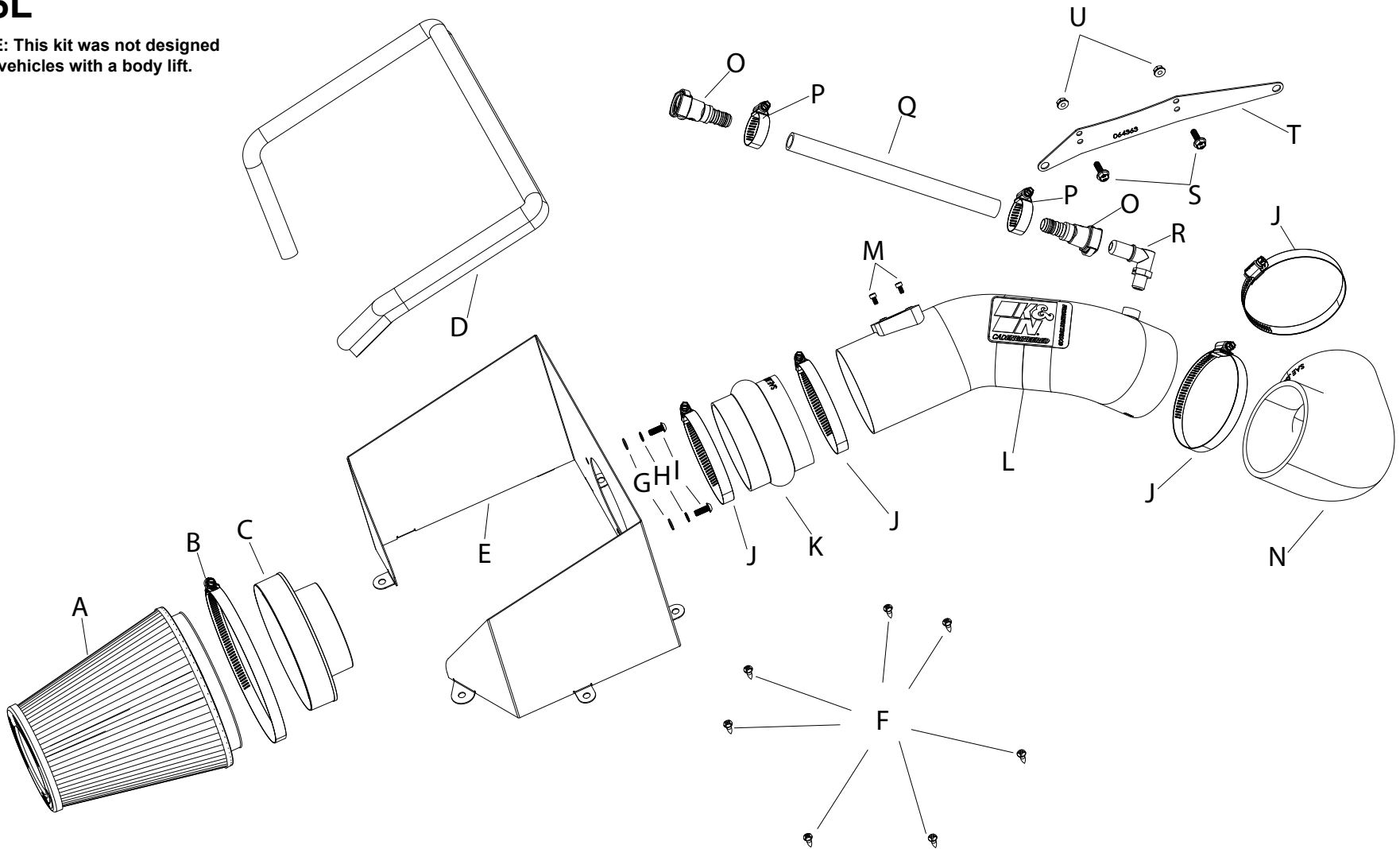

PARTS LIST:

Description	Qty.	Part #	Description	Qty.	Part #	Description	Qty.	Part #
A AIR FILTER	1	RU-1044	H WASHER; M6 SPLIT LOCK ZINC	2	1-3025	O FITTING; 16-14MM PCV	2	08526
B HOSE CLAMP #104	1	08697	I BOLT; M6 X 1 X 16MM BTNHD	2	07730	P HOSE CLAMP; #10 MINI	2	08411
C ADAPTER; #454	1	27300	J HOSE CLAMP; #64 STAINLESS	4	08645	Q HOSE; 3/4"ID X 10"L	1	5-4010
D EDGE TRIM; (42"L)	1	102499	K HOSE; HUMP 4"ID X 3"L	1	08418	R VENT; 90"D, 1/4"NPT, TO .600"	1	82633
E HEAT SHIELD	1	073307	L TUBE; 4"OD X 14"L	1	25840C	S BOLT; M6-1 X 30, HEX/FLANGE	2	1-1016
F SCREW; #12 X 5/8"L	7	07788	M BOLT; M4-.7 X 8MM, ALNHD	2	07733	T BRACKET; HEATER HOSE MNT	1	064363
G WASHER; 6MM FLAT	2	08269	N HOSE; 4"ID, 90 DEG. WRAP	1	08503	U NUT; M6 HEX, SERRATED	2	444.460.04

If you need any assistance please call 1-800-858-3333 to speak with a representative in our Customer Service Center before returning the product.

NOTE: FAILURE TO FOLLOW INSTALLATION INSTRUCTIONS AND NOT USING THE PROVIDED HARDWARE MAY DAMAGE THE INTAKE TUBE, THROTTLE BODY AND ENGINE.

TO START:

1. Turn off the ignition and disconnect the negative battery cable.
NOTE: Disconnecting the negative battery cable erases pre-programmed electronic memories. Write down all memory settings before disconnecting the negative battery cable. Some radios will require an anti-theft code to be entered after the battery is reconnected. The anti-theft code is typically supplied with your owner's manual. In the event your vehicles anti-theft code cannot be recovered, contact an authorized dealership to obtain your vehicles anti-theft code.



2. Separate the coolant pipe from the rear of the intake plenum by disconnecting the retaining clips from the plenum.



3. Push in the locking tabs on the CCV quick connect fittings and then remove the CCV hose assembly from the vehicle.



4. Loosen the hose clamp securing the intake hose to the air filter housing. Disconnect the mass air sensor electrical connection.



5. Loosen the hose clamp that secures the intake plenum to the throttle body. Remove the intake plenum from the vehicle.



6. Loosen the seven screws that secure the upper air filter housing to the lower housing, then remove the upper housing and factory air filter.



7. Disconnect the wiring harness from the intake manifold.



8. Install the provided mounting bracket onto the intake manifold using the provided hardware.



9. Secure the wiring harness and coolant pipe to the mounting bracket as shown.



10. Remove the mass air sensor from the factory air filter housing and install it using the provided hardware.



11. Install the provided 90deg quick connect fitting into the K&N intake tube as shown.



12. Install the provided edge trim onto the heat shield as shown. Some trimming of the edge trim will be necessary.



13. Install the filter adapter into the heat shield and secure with the provided hardware.



14. Install the heat shield assembly onto the factory lower air filter housing and secure with the seven screws provided.



15. Install the angled coupler onto the throttle body but do not tighten the hose clamp at this time.



16. Install the hump coupler onto the filter adapter and secure with the provided hose clamp.



17. Install the intake tube into the couplers, adjust the coupler and tube for best fit and then secure with the provided hose clamps.



18. Assemble the CCV hose with the fittings, hose and clamps provided.



19. Connect the CCV hose assembly to the valve cover and intake tube fittings.



20. Reconnect the mass air sensor electrical connection.



21. Install the K&N air filter onto the adapter and secure with the provided hose clamp.



22. Reconnect the vehicle's negative battery cable. Double check to make sure everything is tight and properly positioned before starting the vehicle.

23. It will be necessary for all K&N® high flow intake systems to be checked periodically for realignment, clearance and tightening of all connections. Failure to follow the above instructions or proper maintenance may void warranty.

ROAD TESTING:

1. Start the engine with the transmission in neutral or park, and the parking brake engaged. Listen for air leaks or odd noises. For air leaks secure hoses and connections. For odd noises, find cause and repair before proceeding. This kit will function identically to the factory system except for being louder and much more responsive.

2. Test drive the vehicle. Listen for odd noises or rattles and fix as necessary.

3. If road test is fine, you can now enjoy the added power and performance from your kit.

4. K&N Engineering, Inc., requires cleaning the intake system's air filter element every 100,000 miles. When used in dusty or off-road environments, our filters will require cleaning more often. We recommend that you visually inspect your filter once every 25,000 miles to determine if the screen is still visible. When the screen is no longer visible some place on the filter element, it is time to clean it. To clean and re-oil, purchase our filter Recharger® service kit, part number 99-5050 or 99-5000 and follow the easy instructions.