

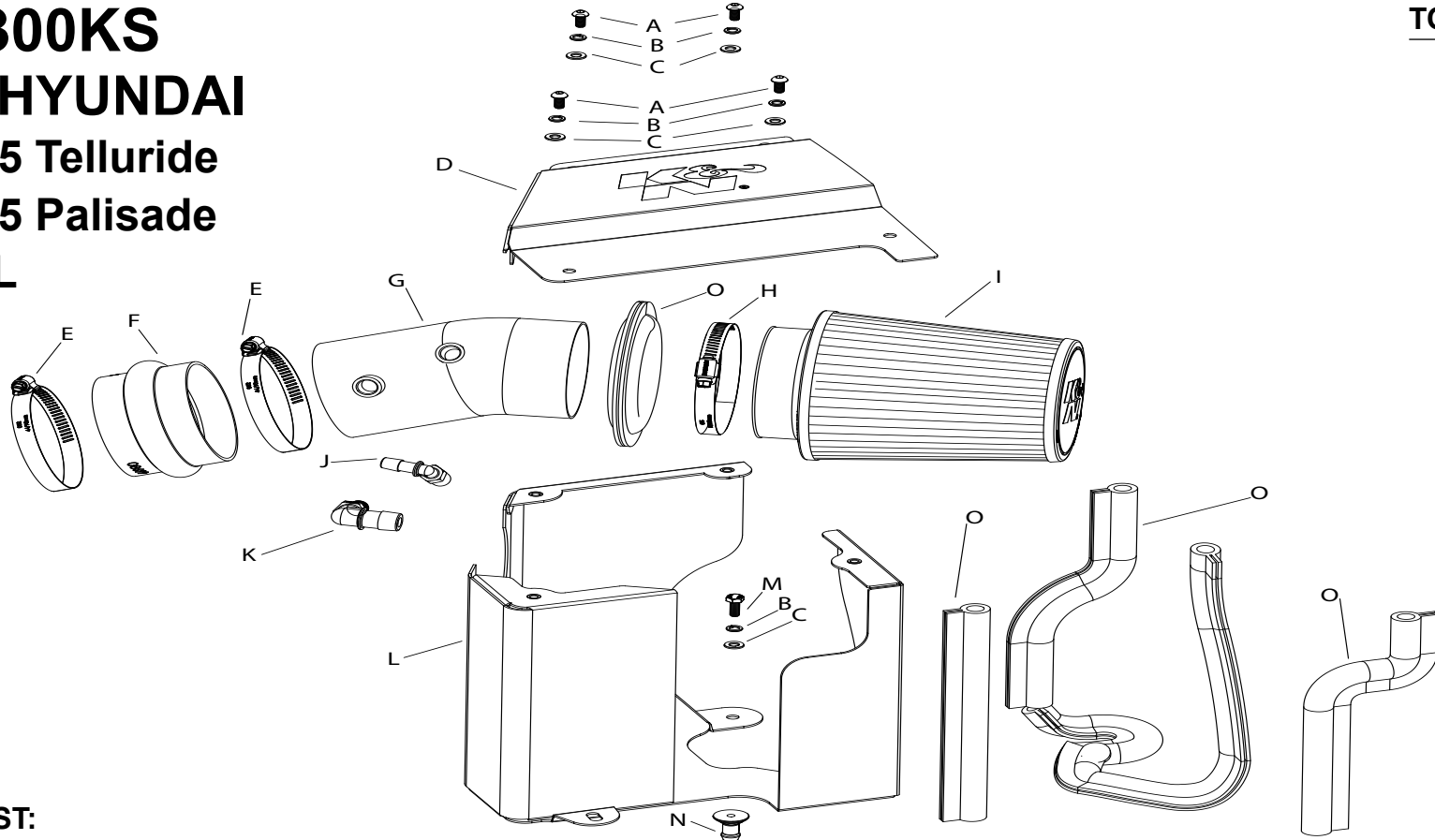

INSTALLATION INSTRUCTIONS

Not legal for sale or use in California on any pollution controlled motor vehicle.

77-5300KS KIA / HYUNDAI 2020-25 Telluride 2020-25 Palisade V6-3.8L



TOOLS NEEDED:

- Flat Blade Screw Driver
- Ratchet
- Extension
- 10mm Socket
- 12mm Socket
- Pliers
- Cutters
- 4mm Allen Key
- 9/16" Wrench
- 3/4" Wrench

PARTS LIST:

Description	Qty.	Part #	Description	Qty.	Part #	Description	Qty.	Part #
A BOLT; M6-1 X 12MM, BTNHD	4	07794	F HOSE; HUMP 3.5"ID X 2.5"L	1	08699	K FITTING; VENT 1/4"NPT	1	08525-1
B WASHER; M6 SPLIT LOCK	5	1-3025	G INTAKE TUBE; (AL)	1	25836S	L HEAT SHIELD	1	07374
C WASHER; 6MM FLAT	5	08269	H HOSE CLAMP; #60	1	08624	M BOLT; M6 X 1 X 12MM, HEXHD	1	07727
D LID	1	07375	I AIR FILTER	1	RU-4630	N MOUNT; PLASTIC AIRBOX	1	8-186-1
E HOSE CLAMP; #56	2	08620	J FITTING; VENT 1/4"NPT 90 DEG	1	08523	O EDGE TRIM; (66"L)	1	102472

If you need any assistance please call 1-800-858-3333 to speak with a representative in our Customer Service Center before returning the product.

NOTE: FAILURE TO FOLLOW INSTALLATION INSTRUCTIONS AND NOT USING THE PROVIDED HARDWARE MAY DAMAGE THE INTAKE TUBE, THROTTLE BODY AND ENGINE.

TO START:

- Turn off the ignition and disconnect the negative battery cable.
NOTE: Disconnecting the negative battery cable erases pre-programmed electronic memories. Write down all memory settings before disconnecting the negative battery cable. Some radios will require an anti-theft code to be entered after the battery is reconnected. The anti-theft code is typically supplied with your owner's manual. In the event your vehicles anti-theft code cannot be recovered, contact an authorized dealership to obtain your vehicles anti-theft code.



- Release the clamps and disconnect the two vent lines from the fittings in the factory intake tube.



- Loosen the two hose clamps that secure the factory intake tube and then remove the intake tube from the vehicle.

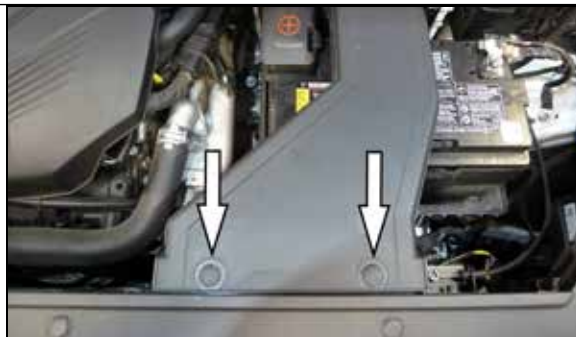

- Remove the two plastic clips that secure the fresh air duct and then remove the duct from the air filter housing and vehicle.



- Remove the battery hold down bolt and pull the battery forward to allow room to remove the factory air filter housing.

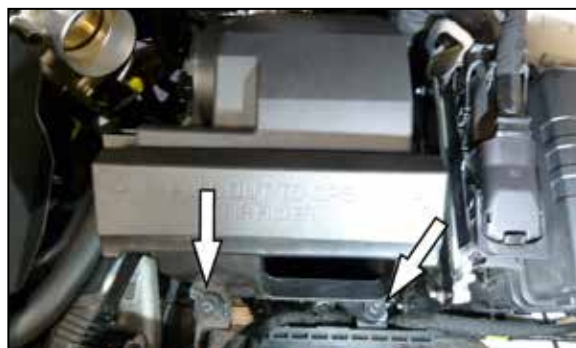

- Remove the two bolts that secure the air filter housing and then remove the air filter housing from the vehicle. **NOTE: these bolts will be used in a later step to secure the K&N heat shield.**



- Install the provided heat shield mounting post onto the heat shield using the provided hardware.



- Cut the provided edge trim to the lengths shown.

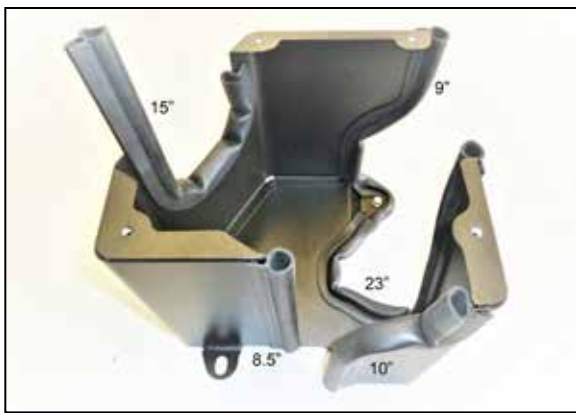

9. Install the trimmed sections of edge trim onto the heat shield as shown.



10. Install the provided hump coupler onto the throttle body and secure with the provided hose clamp.



11. Install the K&N heat shield into position and secure with the factory bolts.



12. Reposition the battery back into position and secure with the factory hold down assembly.



13. Install the provided fittings into the K&N intake tube as shown.

NOTE: NPT fittings are easy to cross thread. Install the vent fitting "hand" tight, then turn it two complete turns with a wrench.



14. Install the intake tube into the hump coupler and connect the vent hoses to the fittings installed into the intake tube and secure with the factory clamps.



15. Install the K&N air filter onto the intake tube, adjust for best fit and then secure the assembly with the hose clamp.



16. Reinstall the factory fresh air intake duct and secure with the factory plastic clips.



17. Reconnect the vehicle's negative battery cable. Double check to make sure everything is tight and properly positioned before starting the vehicle.



18. It will be necessary for all K&N® high flow intake systems to be checked periodically for realignment, clearance and tightening of all connections. Failure to follow the above instructions or proper maintenance may void warranty.

ROAD TESTING:

1. Start the engine with the transmission in neutral or park, and the parking brake engaged. Listen for air leaks or odd noises. For air leaks secure hoses and connections. For odd noises, find cause and repair before proceeding. This kit will function identically to the factory system except for being louder and much more responsive.
2. Test drive the vehicle. Listen for odd noises or rattles and fix as necessary.
3. If road test is fine, you can now enjoy the added power and performance from your kit.
4. K&N Engineering, Inc., requires cleaning the intake system's air filter element every 100,000 miles. When used in dusty or off-road environments, our filters will require cleaning more often. We recommend that you visually inspect your filter once every 25,000 miles to determine if the screen is still visible. When the screen is no longer visible some place on the filter element, it is time to clean it. To clean and re-oil, purchase our filter Recharger® service kit, part number 99-5050 or 99-5000 and follow the easy instructions.