



INTAKE SYSTEMS FOR VEHICLES LISTED ARE 50 STATE LEGAL. SEE KNFILTERS.COM FOR CARB STATUS ON EACH PART FOR A SPECIFIC VEHICLE.

INSTALLATION INSTRUCTIONS

77-6014-1KP

NISSAN

2005-12 Pathfinder

2005-19 Frontier

2005-15 Xterra

V6-4.0L

TOOLS NEEDED:

Ratchet
Extension
10mm Socket
13mm Socket
Phillips Screwdriver
10mm Wrench
9/64"mm Allen Wrench
Flat Blade Screwdriver
Pliers

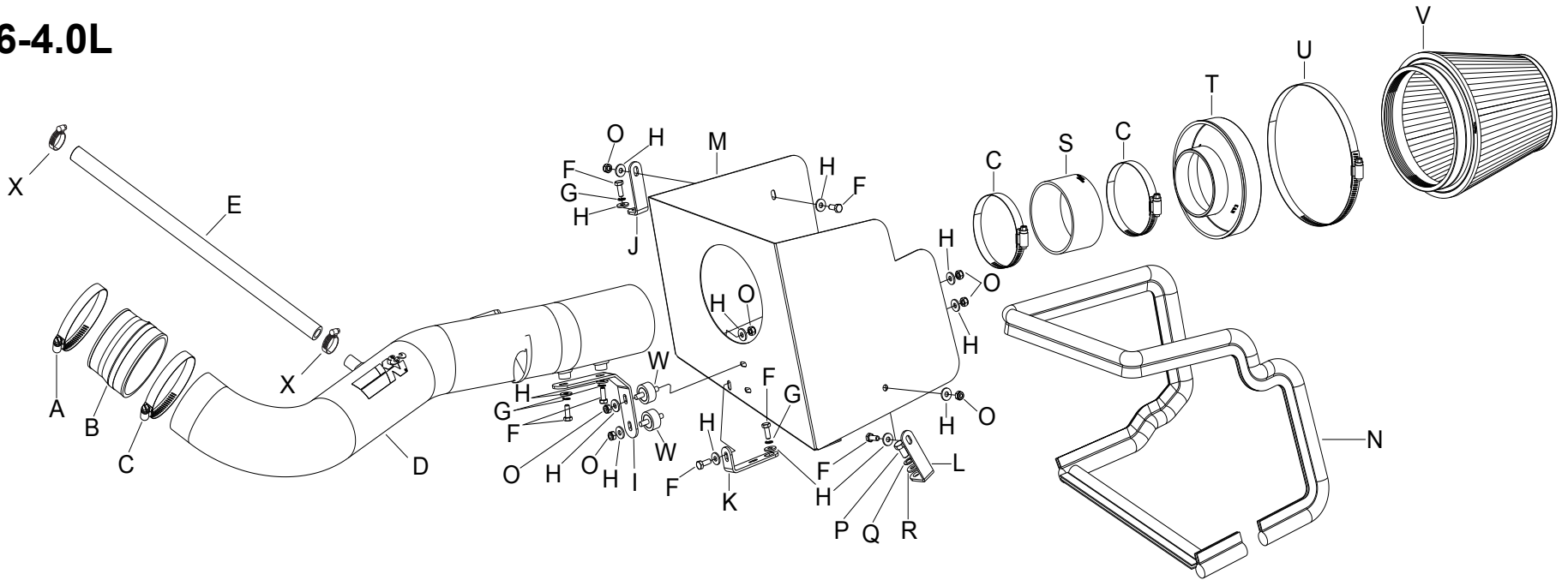

PARTS LIST:

Description	Qty.	Part #	Description	Qty.	Part #	Description	Qty.	Part #
A HOSE CLAMP; #48	1	08601	I BRACKET; "C"	1	070093	Q WASHER; 8MM SPRING (WAVE)	1	08239
B HOSE; 3.5" TO 3"ID X 3"L	1	084055	J BRACKET; "L"	1	07805A	R WASHER; 5/16"OD X 5"OD FLAT	1	08276
C HOSE CLAMP; #56	3	08620	K BRACKET; "L"	1	010051A	S HOSE; 3.5"ID X 2"L	1	08698
D INTAKE TUBE (BRIGHT)	1	27432-1AKP	L BRACKET; "L"	1	070632A	T ADAPTER; 6" FILTER	1	21512-1
E HOSE; 5/8"ID X 17"L	1	5-7017	M HEAT SHIELD	1	07689	U HOSE CLAMP; #104	1	08697
F BOLT; M6-1.00 X 16MM	7	07703	N EDGE TRIM; 83"	1	102503	V AIR FILTER	1	RU-1014
G WASHER; 1/4" LOCK	4	08198	O NUT; 6MM NYLOCK	7	07553	W STUD; M6-1.00 RUBBER	2	07027
H WASHER; 1/4"ID X 5/8"OD	14	08275	P BOLT; 8MM-1.25 X 16MM	1	07844	X HOSE CLAMP; #10 MINI	2	08411

If you need any assistance please call 1-800-858-3333 to speak with a representative in our Customer Service Center before returning the product.

NOTE: FAILURE TO FOLLOW INSTALLATION INSTRUCTIONS AND NOT USING THE PROVIDED HARDWARE MAY DAMAGE THE INTAKE TUBE, THROTTLE BODY AND ENGINE.

TO START:

1. Turn off the ignition and disconnect the negative battery cable.
NOTE: Disconnecting the negative battery cable erases pre-programmed electronic memories. Write down all memory settings before disconnecting the negative battery cable. Some radios will require an anti-theft code to be entered after the battery is reconnected. The anti-theft code is typically supplied with your owner's manual. In the event your vehicles anti-theft code cannot be recovered, contact an authorized dealership to obtain your vehicles anti-theft code.



2. Disconnect the mass air sensor electrical connection and unhook the harness from the airbox.



3. Remove the two bolts shown, which secure the engine cover.



4. Lift firmly on the engine cover to dislodge it from the mounting grommets, and then remove the cover from the engine as shown.



5. Remove the two bolts shown which secure the stock intake tube to the engine.



6. Using pliers, loosen the spring clamp which secures the crankcase vent hose to the valve cover and then remove the hose from the valve cover as shown.



7. Loosen the two hose clamps shown which secure the stock intake tube to the airbox and to the throttle body.



8. Remove the intake tube from the vehicle as shown.



9. Remove the airbox retaining bolt shown.



10. Pull firmly on the airbox to dislodge it from the mounting grommets and remove it from the vehicle. **NOTE: K&N Engineering, Inc., recommends that customers do not discard factory air intake.**



11. Remove the two airbox mounting studs shown from the inner fender.

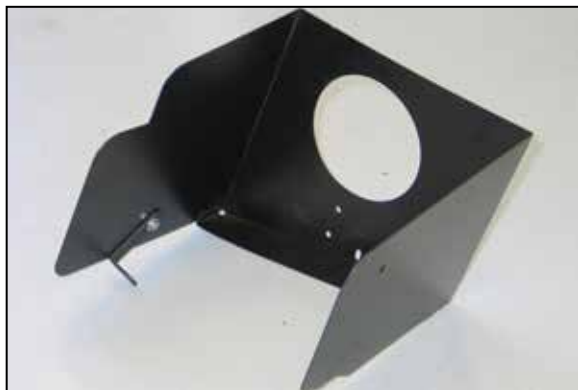

12. Install "L" Bracket (#07805) onto the heat shield with the provided hardware.



13. Install the "L" bracket (010051) onto the heat shield as shown with the provided hardware.



14. Install the edge trim onto the heat shield as shown.

NOTE: Some trimming of the edge trim may be necessary.

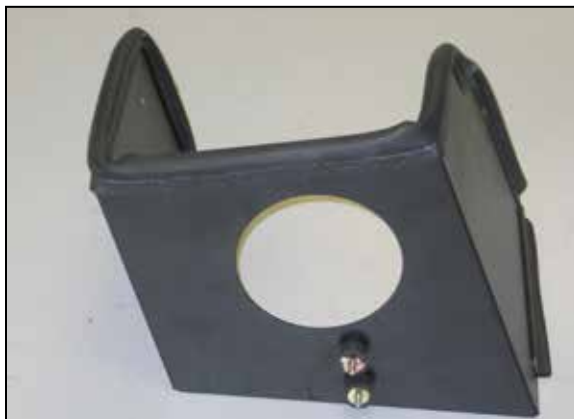

15. Install the provided rubber mounted studs onto the heat shield using the supplied hardware.



16. Attach the provided "C" bracket (070093) to the rubber mounted studs installed in the previous step using the provided hardware.



17. Remove the bolt, which secures the ground strap to the inner fender.

NOTE: This bolt will not be reused.

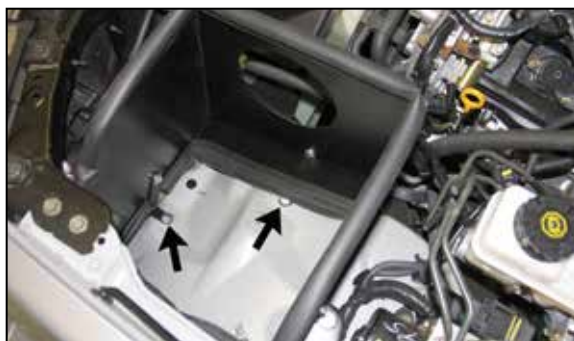

18. Install the heat shield assembly into the vehicle and secure with the provided hardware.

NOTE: Secure the ground strap removed in step #15 onto the lower heat shield mounting bracket.



19. Install the silicone hose (084055) onto the throttle body and secure with the provided hose clamp.



20. Remove the two screws, which secure the mass air sensor to the stock airbox and then remove the mass air sensor from the airbox.



21. Install the mass air sensor into the K&N® intake tube and secure with the screws removed in step #20.



22. Install the K&N® intake tube into the silicone hose at the throttle body and align with the tube mounting bracket installed in step #16. Secure with the provided hardware and hose clamp.



23. Attach the provided crank case vent hose to the valve cover and K&N® intake tube as shown and secure with the provided hose clamps.



24. Install the filter adapter into the air filter as shown and secure with the provided hose clamp.



25. Install the silicone hose (08698) onto the air filter as shown and secure with the provided hose clamp.



26. Install the air filter assembly onto the intake and secure with the provided hose clamp.



27. Reinstall the engine cover removed in step #4 and secure with the factory mounting bolts.



28. Reconnect the mass air sensor electrical connection.



29. Reconnect the vehicle's negative battery cable. Double check to make sure everything is tight and properly positioned before starting the vehicle.

30. The C.A.R.B. exemption sticker, (attached), must be visible under the hood so that an emissions inspector can see it when the vehicle is required to be tested for emissions. California requires testing every two years, other states may vary.

31. It will be necessary for all K&N® high flow intake systems to be checked periodically for realignment, clearance and tightening of all connections. Failure to follow the above instructions or proper maintenance may void warranty.

ROAD TESTING:

1. Start the engine with the transmission in neutral or park, and the parking brake engaged. Listen for air leaks or odd noises. For air leaks secure hoses and connections. For odd noises, find cause and repair before proceeding. This kit will function identically to the factory system except for being louder and much more responsive.
2. Test drive the vehicle. Listen for odd noises or rattles and fix as necessary.
3. If road test is fine, you can now enjoy the added power and performance from your kit.
4. K&N Engineering, Inc., requires cleaning the intake system's air filter element every 100,000 miles. When used in dusty or off-road environments, our filters will require cleaning more often. We recommend that you visually inspect your filter once every 25,000 miles to determine if the screen is still visible. When the screen is no longer visible some place on the filter element, it is time to clean it. To clean and re-oil, purchase our filter Recharger® service kit, part number 99-5050 or 99-5000 and follow the easy instructions.

INTAKE SYSTEMS FOR VEHICLES LISTED ARE 50 STATE LEGAL. SEE KNFILTERS.COM FOR CARB STATUS ON EACH PART FOR A SPECIFIC VEHICLE.