



Oil Separator INSTALLATION INSTRUCTIONS

81-0809

FORD

2021-23 Bronco 2.3L

(October 2021 Forward Production dates Only)

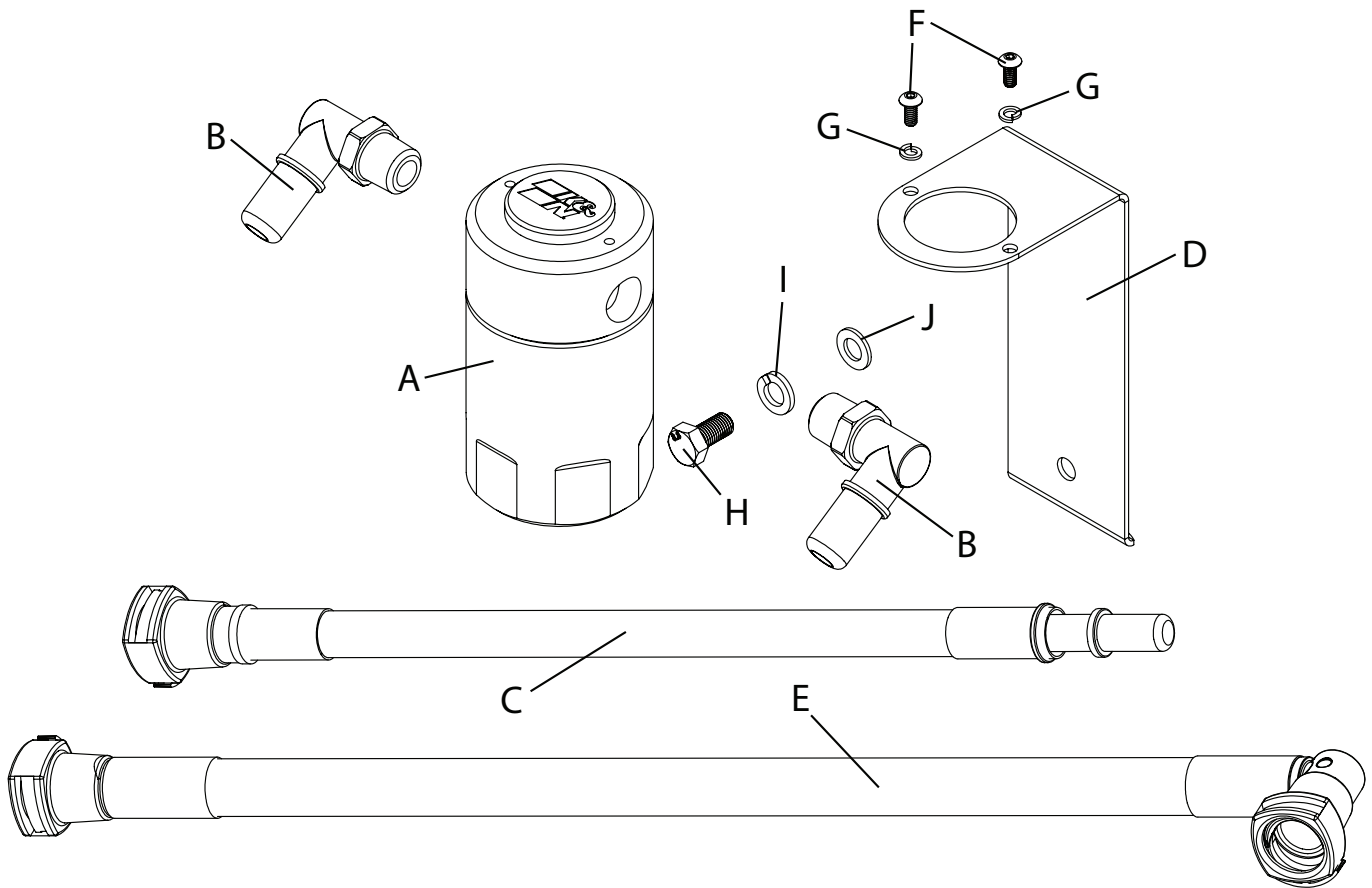

PARTS LIST:

	Description	Qty.	Part #
A	CATCH CAN; 2.5"OD X 4.5"H	1	85-6860
B	QUICK RELEASE; 3/8" NPT 90°	2	082634
C	HOSE; 1/2"ID X 12"L	1	084159
D	BRACKET	1	010230
E	HOSE; 1/2"ID X 17"L	1	084160
F	BUTTON HEAD CAP SCREW	2	91255A192
G	18-8 SPLIT LOCK WASHER	2	92146A618
H	M8 X 1.25 X 16MM BOLT	1	077002
I	M8 SPLIT LOCK WASHER	1	AEM-1-306
J	8MM FLAT WASHER	1	08272

TOOLS NEEDED:

2.5mm Allen key
Ratchet
13mm Socket
13/16" Wrench

1. Verify you have all the parts included in the kit.



2. Remove factory PCV line by pulling tabs and removing it from the PCV valve and intake manifold



3. Assemble the quick disconnect fittings to the top of the air/oil separator as shown. It is required to use Teflon tape on the fittings to ensure a proper seal. **NOTE: DO NOT over-tighten fittings in top of oil separator.**



4. Install mounting bracket to brake distribution block using M8 bolt, washer and lock washer as shown.

5. Mount the canister to the bracket using the two button head screws and lock washers.



6. Install hoses on to oil separator as shown. Mount the hose with female fitting to the manifold. Mount the hose with male fitting to the PCV line going to back of the engine. **NOTE: Lightly coat the O-Ring with oil to insert easily.**

7. We recommend to check the oil separator every 10,000 miles or 12 months (sooner if vehicle is driven in harsher conditions such as towing or off-road).