



UNDER THE HOOD. ABOVE THE REST.

INSTALLATION INSTRUCTIONS

21-8130DC (Gun Metal Gray Finish)

FORD

2017-23 F150

2017-23 F150 Raptor

2021-22 Expedition

V6-3.5L EcoBoost

TOOLS NEEDED:

Flat Blade Screw driver
4mm allen key

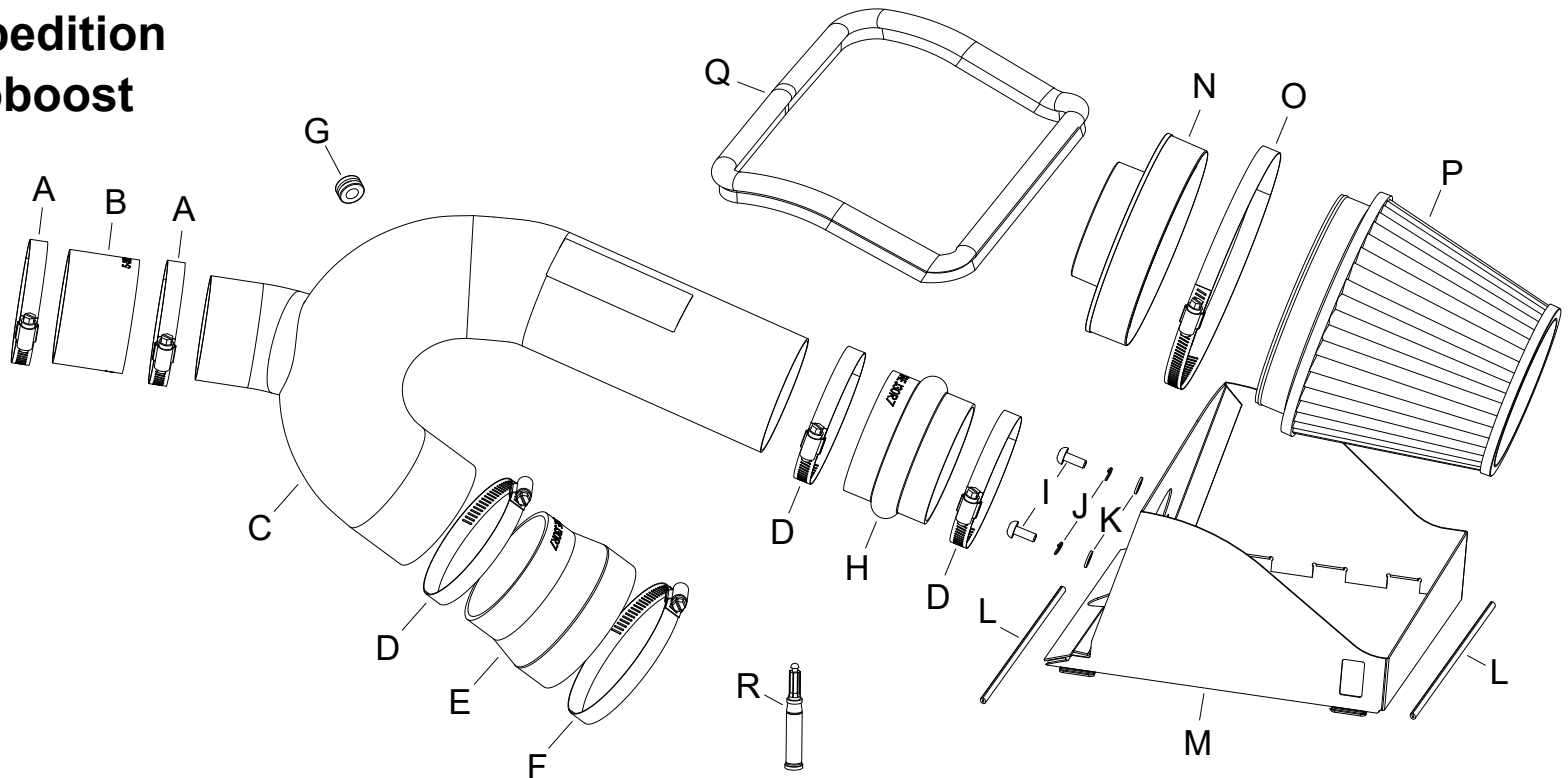

NOT LEGAL FOR SALE OR USE ON ANY POLLUTION CONTROLLED MOTOR VEHICLE IN CALIFORNIA OR STATES ADOPTING CALIFORNIA EMISSION PROCEDURES.
See aemintakes.com for CARB status on each part for a specific vehicle

PARTS LIST:

Description	Qty.	Part #	Description	Qty.	Part #	Description	Qty.	Part #
A HOSE CLAMP: #48	2	08601	G GROMMET; 1"OD, 1/2"ID	1	08064	M HEAT SHIELD	1	20-8617
B HOSE; 3"ID X 2", SILICONE BLK	1	5-302	H HOSE; HUMP 3.5"ID X 2.5"L	1	08699	N ADAPTER; UNIVERSAL, 6"	1	21512-1
C INTAKE TUBE; 3.5"OD X 40"	1	2-1596C	I BOLT: M6 X 1 X 16MM BTNHD	2	07730	O 1/2" BNDHOSE CLAMP, 4.125	1	94104
D HOSE CLAMP; #56	3	08620	J WASHER, M6 SPLIT LOCK ZINC	2	1-3025	P AIR FILTER	1	21-210EDK
E HOSE; 4"ID TO 3.5"ID X 3"L	1	08497	K WASHER: 6MM FLAT	2	08269	Q EDGE TRIM; (39"L)	1	102496
F HOSE CLAMP #64 STAINLESS	1	08645	L EDGE TRIM; (19"L)	1	102451	R SUPER GLUE, 3G DRIP PROOF	1	409

If you need any assistance please call 1-800-858-3333 to speak with a representative in our Customer Service Center before returning the product.

Read and understand these instructions BEFORE attempting to install this product. Failure to follow installation instructions and not using the provided hardware may damage the intake tube, throttle body and engine.

TO START:

1. Turn off the ignition and disconnect the negative battery cable.
NOTE: Disconnecting the negative battery cable erases pre-programmed electronic memories. Write down all memory settings before disconnecting the negative battery cable. Some radios will require an anti-theft code to be entered after the battery is reconnected. The anti-theft code is typically supplied with your owner's manual. In the event your vehicles anti-theft code cannot be recovered, contact an authorized dealership to obtain your vehicles anti-theft code.



2. Disconnect the inlet air temperature sensor electrical connect and remove the tape around the harness connector.



3. Loosen the hose clamp that secures the factory intake tube to the upper air filter housing.



4. Release the locking clips that secure the upper air filter housing to the lower housing, then lift the upper housing and remove it from the vehicle. Remove the factory air filter from the vehicle.
NOTE: AEM recommends that customers do not discard factory air intake.



5. Loosen the two hose clamps that secure the factory intake tube to the turbo inlets and remove the factory tube from the vehicle.

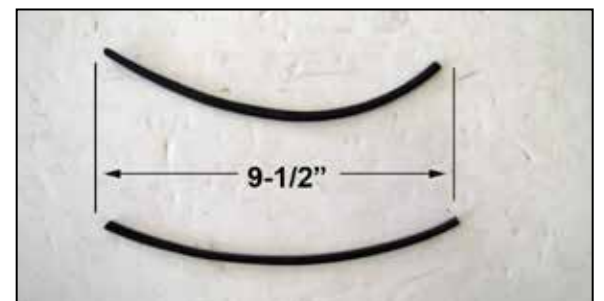

6. Cut the provided edge trim into two sections 9.5" long.



7. Install the small edge trim onto the bottom of the heat shield as shown using the provided super glue to secure it in place.



8. Install the provided bulb edge trim onto the top of the heat shield as shown.

NOTE: Some trimming of the edge trim will be necessary.



9. Install the filter adapter into the heat shield and secure with the provided hardware.



10. Install the air filter onto the filter adapter and secure with the provided hose clamp.



11. Install the heat shield/filter assembly onto the factory lower air filter housing and secure with the factory retaining clips.



12. Install the provided hump coupler (08699) onto the filter adapter and secure with the provided hose clamp.



13. Install the provided coupler (08497) onto the driver's side turbo inlet tube and secure with the provided hose clamp.



14. Install the provided coupler hose (5-302) onto the passenger side turbo inlet hose and secure with the provided hose clamp.



15. Remove the inlet temperature sensor from the factory intake tube.



16. Install the provided grommet and inlet air temperature sensor into the AEM® intake tube as show.



17. Install the AEM® intake tube into the couplers at the turbo inlet tubes and then into the coupler at the filter adapter, adjust the tubes for best fit and then secure with the provided hose clamps.



18. Reconnect the inlet air temperature sensor electrical connection.



Reassemble Vehicle

Position the inlet pipes for the best fitment. Be sure that the pipes or any other components do not contact any part of the vehicle. Tighten the rubber mount, all bolts, and hose clamps. Check for proper hood clearance. Re-adjust pipes if necessary and re-tighten them. Inspect the engine bay for any loose tools and check that all fasteners that were moved or removed are properly tightened. Reconnect negative battery terminal and start engine. Let the vehicle idle for 3 minutes. Perform a final inspection before driving the vehicle.

Service and Maintenance

AEM Induction Systems requires cleaning the intake system's air filter element every 100,000 miles. When used in dusty or off-road environments, our filters will require cleaning more often. We recommend that you visually inspect your filter once every 25,000 miles to determine if the screen is still visible. When the screen is no longer visible some place on the filter element, it is time to clean it. To clean, purchase our Synthetic air filter cleaner, part number AEM-1-1000 and follow the easy instructions. Use window cleaner to clean your powder coated AEM® intake tube.

NOTE: DO NOT USE aluminum polish on powder coated AEM® intake tubes.

NOT LEGAL FOR SALE OR USE ON ANY POLLUTION CONTROLLED MOTOR VEHICLE IN CALIFORNIA OR STATES ADOPTING CALIFORNIA EMISSION PROCEDURES.

See aemintakes.com for CARB status on each part for a specific vehicle

AEM Air Intake System Warranty Policy

AEM® warrants that its intake systems will last for the life of your vehicle. AEM will not honor this warranty due to mechanical damage (i.e. improper installation or fitment), damage from misuse, accidents or flying debris. AEM will not warrant its powder coating if the finish has been cleaned with a hydrocarbon-based solvent. The powder coating should only be cleaned with a mild soap and water solution. Proof of purchase of both the vehicle and AEM intake system is required for redemption of a warranty claim.

This warranty is limited to the repair or replacement of the AEM part. In no event shall this warranty exceed the original purchase price of the AEM part nor shall AEM be responsible for special, incidental or consequential damages or cost incurred due to the failure of this product. Warranty claims to AEM must be transportation prepaid and accompanied with dated proof of purchase. This warranty applies only to the original purchaser of product and is nontransferable. Improper use or installation, use for racing, accident, abuse, unauthorized repairs or alterations voids this warranty. AEM disclaims any liability for consequential damages due to breach of any written or implied warranty on all products manufactured by AEM. Warranty returns will only be accepted by AEM when accompanied by a valid Return Merchandise Authorization (RMA) number. Credit for defective products will be issued pending inspection. Product must be received by AEM within 30 days of the date RMA is issued.

If you have a warranty issue, please call (800) 992-3000 and our customer service department will assist you. A proof of purchase is required for all AEM warranty claims.