

Airaid

INSTALLATION INSTRUCTIONS

314-732 854-364 Airaid Oiled Media Filter

2012-18 / JEEP / WRANGLER

V6 / 3.6L

NOT LEGAL FOR SALE OR USE ON ANY POLLUTION CONTROLLED MOTOR VEHICLE IN CALIFORNIA OR STATES ADOPTING CALIFORNIA EMISSION PROCEDURES.

See Airaid.com for CARB status on each part for a specific vehicle

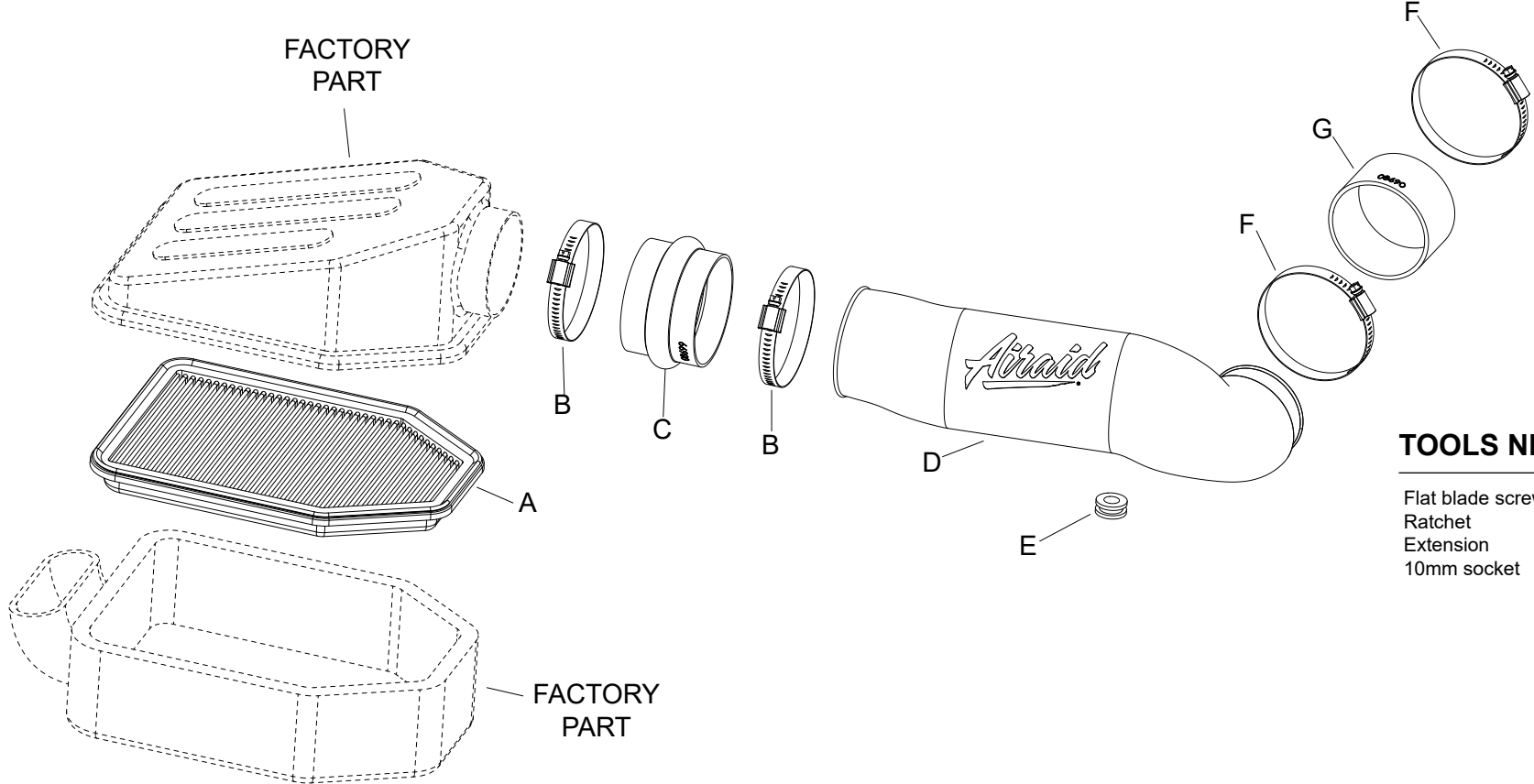

TOOLS NEEDED:

Flat blade screw driver
Ratchet
Extension
10mm socket

COMPONENT IDENTIFICATION

Description	Qty.	Part #	Description	Qty.	Part #	Description	Qty.	Part #
A AIR FILTER	1	854-364	D TUBE; AIRAID "OS"	1	087497	G HOSE; 3.25"ID X 2"L	1	08690
B HOSE CLAMP #56	2	08620	E GROMMET; 1/2"ID	1	KITGRMT03			
C HOSE; HUMP 3.5"ID X 2.5"L	1	08699	F HOSE CLAMP #52	2	08610			

Full color instructions can be viewed on our web site at Airaid.com. If you need any assistance please call 1-800-498-6951 to speak with a representative in our Customer Service Center before returning the product.

TO START:

1. Turn off the ignition and disconnect the negative battery cable.

NOTE: Disconnecting the negative battery cable erases pre-programmed electronic memories. Write down all memory settings before disconnecting the negative battery cable. Some radios will require an anti-theft code to be entered after the battery is reconnected. The anti-theft code is typically supplied with your owner's manual. In the event your vehicles anti-theft code cannot be recovered, contact an authorized dealership to obtain your vehicles anti-theft code.



2. Lift off the decorative engine cover and set aside.



3. Disconnect the IAT sensor electrical connection.



4. Remove the two bolts that secure the intake tube to the core support. Loosen the two hose clamps that secure the intake tube to the throttle body and air filter housing and then remove the intake tube from the vehicle.



5. Twist the IAT sensor counter clockwise and remove it from the factory intake tube.



6. Remove the O-ring from the IAT sensor and then install it into the AIRAID intake tube using the provided grommet.

Continued...



7. Remove the upper air filter housing and then remove the factory air filter. Install the AIRAID air filter and then reinstall the upper air filter housing.

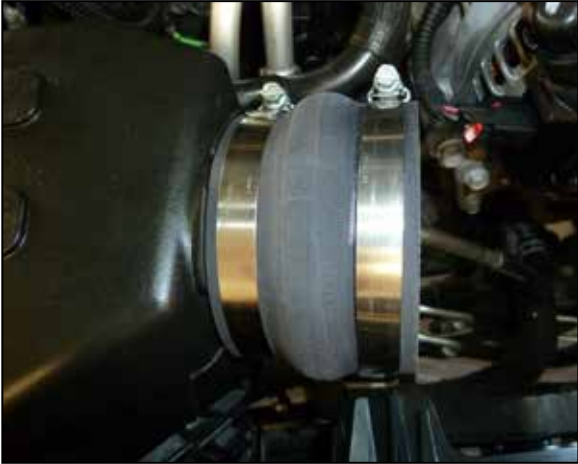

8. Install the provided hump coupler onto the air filter housing and secure with the provided hose clamp.



9. Install the provided straight coupler onto the throttle body and secure with the provided hose clamp.



10. Install the AIRAID intake tube into the hump coupler and then into the straight coupler, align for best fit and then secure with the provided hose clamps.



11. Reconnect the IAT electrical connection.



12. Reinstall the decorative engine cover.

13. Double check your work!

Make sure there is no foreign material in the intake path. Make sure all clamps, hoses, bolts, and screws are tight. Double check the hood clearance! **Reconnect the negative battery cable!**

Thank you for purchasing the Airaid Intake System. Contact Airaid @ (800) 498-6951 8:00 AM - 5:00 PM MST weekdays for questions regarding fit or instructions that are not clear to you. Your Airaid Intake System was carefully inspected and packaged. Check that no parts are missing, or were damaged during shipping. If any parts are missing, contact Airaid. The air filter element is protected from direct exposure to water and debris; care should be taken not to drive through deep water. **WATER INGESTION IS THE DRIVERS RESPONSIBILITY!** The air filter is reusable and should be cleaned periodically.

For your Oiled media filter we offer the Airaid Tune Up Kit!



P/N 790-551 Aerosol Spray
P/N 790-550 Squeeze Spray



NOT LEGAL FOR SALE OR USE ON ANY POLLUTION CONTROLLED MOTOR VEHICLE IN CALIFORNIA OR STATES ADOPTING CALIFORNIA EMISSION PROCEDURES.

See Airaid.com for CARB status on each part for a specific vehicle

SynthaMax

Synthamax Air Filters **do not** require oil. Service air filter as needed by cleaning with common non-petroleum all-purpose household cleaner and water. Simple Green®, Formula 409® or equivalent works great. Apply cleaner to outside of air filter and allow to soak. Then flush filter clean from the inside out with a garden hose and repeat steps if necessary. Do not apply high pressure water or air to clean filter. Allow filter to air dry and reinstall.